



www.asoc.fsnet.co.uk

AUTO-SLEEPER OWNERS' CLUB

A Company Limited by Guarantee.

Registered Office: Orchard Works, Willersey, Nr. Broadway,
Worcs., WR12 7QF. Registered No: 4616969



NEWSLETTER 175

APRIL 2003

Hello.

The Show at the N.E.C. has come and gone and the Club was represented on the A-S stand. I thought that the show of vans which A-S had produced was very interesting indeed and I understand that trade was pretty good throughout the week.

Sheila and I were quite taken with the Nuevo ES on the Peugeot chassis because we are restricted in the length of van that we can accommodate where we park it. Would you believe that the Nuevo is about 4" shorter than our Clubman? It certainly surprised us. Also, at long last, there is a van with four forward facing seats available, each with the safety belt fitted. With the driving seats capable of being turned around to make a very pleasant sitting room / dining room and the Peugeot gear stick being away from the floor, it makes a very comfortable "living" van. But we are not thinking of changing over yet, with a possible exception if "ERNIE" or "Lotto" should turn up trumps with a suitable contribution. And even then we would need to consider it in depth.

We particularly liked the fridge which is installed with a full width freezer area and the arrangement of a pull-out extra working surface from just under the top of the fridge surround. Good thinking, someone!

We also noticed a rather large motor yacht on show. We didn't try to find out the cost because we thought that if we had to ask about it we just couldn't afford it! In our imagination, it would make any of the A-S vans, even the Luxor, look a very attractive price. Even the narrow boats on show cost quite a bit. So we shall just have to stick with our motorhome and carry on enjoying it!

-----oooOOOooo-----

Window Problems

My wife and I own a 4 year old VW Trident and have recently noticed that the Black Coating of the side window at the offside rear of the vehicle has "crazed". Having contacted A-S, they have told me that they have had some reports of this before and have said that the coating now used has been improved.

To correct the problem on my van, they have suggested taking the vehicle to their service centre where they would arrange for a windscreen contractor to replace the window. This would involve having the vehicle overnight and would incur a cost of £100.00 which they say is solely for the contractor.

Has any other member experienced similar problems with this black coating and, if they have, how did they resolve it. As I said the van is only 4 years old and it seems a bit odd that the coating has now been removed, when surely this coating has been used for many years. I also asked if they knew of a Manchester based contractor who could do this work, but they did not respond to this question. It is somewhat inconvenient for me to take the vehicle to the A-S Service centre.

Ian McGregor

-----oooOOOooo-----

Magic Carpet - part 2.

Margaret and I first "hit the road" way back in 1954 on a 500cc B.S.A. twin. We added a sidecar for the children and towed a trailer behind the outfit for the camping gear. Our first accident was in 1974 and the one in 2002 (mentioned last month) was our second. So if accidents happen to us every 30 years or so we won't be around for number three! We plan to head south next autumn but will return to UK in time for a family party in mid March for *Margaret's* big Seven-0 birthday. Later in 2004 it will be our Golden Wedding Anniversary so it will be a special time for us. (Because that milestone has been mentioned I must record that this year I shall get my free TV licence!) Should anyone fancy trying our back door route into Spain, the Camping Municipal at St. Beat is not 5 star but it is OK for an overnight stop. There are a lot of static vans and we usually tuck ourselves alongside the infant river Garonne where it begins its journey to Bordeaux and the sea. In the off season reception is only open for an hour in the evening or sometimes the warden calls at the van.

If you enjoy travelling at high speed on motorways or dual carriageways this route is not for you. We enjoy country roads and taking in the wonderful scenery. And when you no longer have to join the rat race to work, does it matter if you are a day late getting wherever you are going?

The Vielha tunnel is about 3 miles long, it is lit and it is free. No hairpin bends, just a steep climb out of Vielha town but our 2.5 diesel Transit (no turbo) pulled the Meteorite up to the tunnel without a problem when we took it to Spain in 1998. In Lerida follow signs for the motorway Barcelona - Zaragoza through the city centre (lots of traffic lights) and upon getting to the southern side of the city follow the motorway overhead signs and look for one with Flix N.230 on it. Outward for about 3 miles and just before the toll booths the N.230 turns off to the right. Again lovely scenery once you leave Lerida and you follow the Ebro valley all the way to Tortosa and the

very busy N.340 that goes along the east coast of Spain. And yes, there is a little Spanish town called Flix!

There are now so many 'snowbirds' heading south these days that to get a good pitch you have to reserve one before you come home. We moved campsites in 2002 and to get a pitch large enough for the Magic Carpet and the Meteorite it was necessary to be there in late September. So we went early and came home early – hence this story!

Margaret & Arthur Fairburn

-----oooOOOooo-----

Chairman's Chat

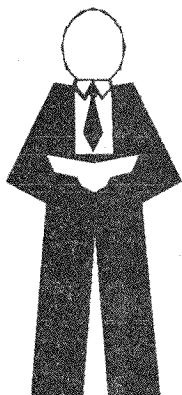

Many members will have seen reports in the motorhome press of the Club's incorporation as a Company Limited by Guarantee, together with a colour photograph of Founder Vice-Presidents *Rita Daley* and *John Cox* signing the Memorandum and Articles of Association, with our President *Charles Trevelyan* witnessing their signatures.

Unfortunately, one magazine, under the heading "ASOC Ltd", described the Club as a "limited business", and later referred to it as "the company club" in an item about the recent survey of members.

The word "Limited" (or its abbreviation) is not part of the Club's name: because of the Club's objectives, we are exempt from using this word, and our solicitor made the necessary statutory declaration to Companies House to secure this exemption.

We are not a "limited business": in other words, the Club does not exist for the purpose of trading (other, of course, than the sale of Club regalia to members). We are not a "company Club": although we accepted the kind offer of Auto-Sleepers Limited to use their premises as our registered office, the Club remains autonomous, whilst continuing to enjoy close links and co-operation with the company.

As has always been said, members will notice very little difference to the everyday life of the Club from the change of status. Perhaps the only visible difference is the inclusion of the statement on the cover of your Newsletter, which it is a legal requirement to include on certain documents, including the Club's letterhead - one reason for limiting the use of that letterhead to Committee members or by express permission of a Committee member (Bylaw no. 3).

Ray Whiley

That same magazine is also showing the wrong name and address for our Membership Secretary who is, of course, *Norma Caley*. And just to compound that magazine's problems, their editorial staff couldn't even get the correct name for the picture of the vehicle they show on the cover. I've never seen a "Clubman Executive", especially with a Peugeot badge - have you?

====oooOOOooo====

PARISIAN AUTUMN

ASOC has teamed up with GB Privilege Ltd - Britain's premier motorhome tour operator - to offer it's members a truly wonderful 5-day trip to Paris in September 2003 at a special price of £295 for a motorhome with 2 people. The tour is entitled "Parisian Autumn" and has been carefully planned to allow all Club members to participate.

Club members who are not very experienced in driving on the continent will benefit from having an experienced Tour Director to follow every step of the way, while those with more confidence can simply take advantage of the incredible value. All participants will enjoy the good company in the evenings as well as the fabulous Parisian evening on Monday, 29th September. The tried & tested GB Privilege system works like this:

- A) Each participant receives a return ticket for their motorhome plus passengers on a ferry from Dover to Calais.
- B) One experienced Tour Director is allocated for each 20 motorhomes who want their assistance.
- C) Each participant receives a detailed route plan, enabling everybody to find each campsite easily.
- D) No more than 20 vehicles travel together.
- E) Each participant receives a comprehensive information pack to minimise any problems that may be caused through unfamiliarity with French campsites.

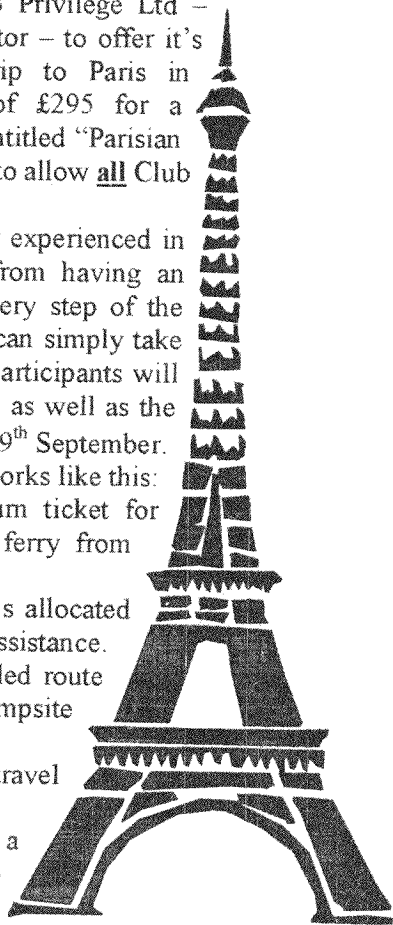

The highlight of the "Parisian Autumn" tour will be a wonderful night out in a special riverside restaurant. At the end of the 19th century, many Parisians would take the opportunity to get some fresh air into their lungs on their day off work and, being French, they would enjoy a good meal with music and dancing. About 400 restaurants sprang up on the outskirts of Paris to cater for this market - they were called "Guingettes" and offered really wholesome food and musical entertainment. Today only about 12 Guingettes are still in existence and they continue to offer the same type of menus and entertainment as were available 100 years ago.

On Monday evening we will take a 10-minute stroll to the Guingette to enjoy a selection of aperitifs, followed by a tasty 5-course dinner (with virtually unlimited wine) in the wonderful ambience created by traditional Parisian songs from a small orchestra and a singer. After dinner the orchestra will continue playing until the small hours of the morning so you can dance the night away! If you start to feel tired, simply stroll back to your motorhome.

We need 80 people before they will allow us to use the ballroom and provide an orchestra, but if we don't achieve this number we will still have exactly the same meal in the riverside restaurant, accompanied by a strolling accordion player and singer. The menu will comprise assorted aperitifs (as many as you want), followed by Hors D'œuvres, a fish course, a main course, a cheese course, assorted deserts and coffee. Virtually unlimited bread, red and white wine will be served throughout the dinner.

The complete itinerary is as follows:

27th September 2003: Saturday

The tour directors will stay the night at a campsite near Folkestone in Kent. If any tour participants want to meet up with them, they can stay at the same site. Fees for this campsite are not included in the tour price.

28th September 2003: Sunday

This morning we will catch a ferry from Dover to Calais. After disembarking, we have a drive of about 100 miles, nearly all on motorway, to arrive at our first campsite near the town of Peronne. Inexperienced drivers will be given the opportunity to "follow the leader", while those with more confidence can make their own way to the campsite. This evening the campsite will welcome ASOC members with a drinks reception.

29th September 2003: Monday

Today we drive to our site near Paris. We have all day to make the journey, so it can be easily achieved at a very leisurely pace. This evening we will have our fabulous night out at the Guingette.

30th September 2003: Tuesday

A completely free day to explore, relax or sleep!

1st October 2003: Wednesday

Paris is easily reached by public transport from the campsite for those who want to visit this most beautiful of cities. Alternatively, travel in the opposite direction and you will reach Disney within one hour.

2nd October 2003: Thursday

This morning we head back towards the north coast for our last stop at a campsite near Boulogne. We suggest you do some of your shopping today, to avoid a rush in the morning. This evening the tour director will organise an optional last night dinner with wine in a traditional French restaurant. You will be given full details, including the menu, during our stay in Paris.

3rd October 2003: Friday

Calais is less than one hour's drive away, so we will have enough time to do some last minute shopping. Don't forget to fill up with cheap diesel before boarding the ferry.

PRICE £295 PER MOTORHOME WITH 2 PEOPLE.

Included in the price

- i) Return ticket on the Dover-Calais ferry for a motorhome up to 6.0 metres long plus all passengers. (Extra charge of £25 per metre or part metre for vehicles over 6 metres length)
- ii) 3 nights at Paris campsite, with 220 volt hook-ups
- iii) 1 night at Peronne campsite, with 220 volt hook-ups
- iv) 1 night at Boulogne campsite with 220 volt hook-ups
- v) "19th century" 5-course Parisian dinner alongside the River Mame, with live traditional musical accompaniment. The meal will be preceded by unlimited aperitifs, accompanied by wine and followed by coffee and music for dancing (if minimum numbers are attained)
- vi) Services of GB Privilege tour directors (1 per 20 motorhomes) for the duration of the tour

To receive a booking form for the "Parisian Autumn" tour, please send your name and address to:

GB Privilege Ltd., 3 The Fields, Tacolneston, Norfolk NR16 1DG
Tel: 01953-789661. Fax: 01953-789519. Email: gbprivilege@yahoo.com

-----oooOOOooo-----

TOPAZ OR NOT TO TOPAZ

With the monthly magazines now giving us a preview of the new VW T5 we thought it might be appropriate to reflect on our 8 years of owning a Topaz and hope that it will encourage other members to also make comments which may hopefully help the factory to improve, and ensure that there is a replacement.

Our van is a 4 berth '95 model with 2.4D engine, chosen because the 4 berth gives us greater flexibility for storage in the Luton. We use two plastic crates to hold personal belongings which can be easily lifted down and store the bedding behind them. A matching curtain across hides the gear and looks good.

The conversion is great, it suits us down to the ground and I hope any replacement will continue with the same basic layout. The tail gate is very useful; we do a lot of walking and we can take off our wet clothes and muddy boots under the canopy, stow the boots one pair in the gas locker and one pair in the cassette toilet compartment, put wet clothes above the loo and enter the van at the back, so keeping the living area warm and dry.

We always use a double bed, having tried the singles we find that they are too narrow. We sleep with our heads to the front of the van, and use a camping mat to even out the joins in the seats, use a fitted bottom sheet, top sheet and quilt. As we get older this arrangement enables either of us to visit the toilet without disturbing the other. We have made one modification to the bed as supplied by A-S; the section which fits between the front seats was difficult to engage with the track provided, also the track was not strong enough to hold our weight. We have fitted two screw-in legs and this now works perfectly, in fact we now have an extra stool for use when entertaining.

There is very little we dislike on the van, the roof lights would not be our choice, many times in high winds we have prayed that they would not disappear. Similarly with the black insulating panels on the outside, which are always working loose and have to be re-fixed. We have seen several A-S conversions that have lost these panels in high winds. The little widows at the side left when fixing these side panels also seem to be unnecessary, the kitchen tops cover them when on site, and the blinds are impossible to get at, to replace, so we keep them closed all the time. There is also a great risk of damp getting in behind the black panel as the flexing of the panels in wind breaks the seal with the van window.

One of major problems on trips abroad has been gas. With limited storage and British bottles not obtainable, we have often been in trouble especially if the weather turns cold. The gas compartment will not take any continental bottle except Camping Gaz and that is no good in cold weather. We did find a small bottle in Norway, also available in Denmark but not Sweden, but this could only be used with the regulator poking through the access into the wardrobe. Currently we have standardised on carrying one 3.9kg Calor Propane cylinder and one 907 Camping Gaz Cylinder, with a changeover valve. This enables us to cope in most of Europe for most occasions.

After a trip to Norway a couple of years ago we did contemplate replacing the van as the 2.4D engine did struggle on the mountain roads. However after looking at the new Topaz with its improvements(?), we decided to stay with our current model and fit a TB turbo. What a difference, the van is now a great pleasure to drive. We have also had fitted Cruise Control by Conrad Anderson.

Why did we not like the new Topaz? Well, with the new bathroom mouldings etc. we felt that the opportunities for using all the spare space in the bilges was lost. We also did not like the crockery taking up a whole cupboard.

So what would we like to see from a new replacement? With a small van we would plead for the design to make as much use as possible of the available storage potential. Please leave access to all those nooks and crannies, especially for the likes of muddy walking boots. Please keep the layout as it currently exists, but as a suggestion use some of the ideas employed in the new Duetto. We would be very happy to see one large roof light, no high level side windows, and storage cupboards all along the side. We notice in the latest A-S Topaz brochure diesel heating is provided; this would solve all the gas availability problems we have had on our continental trips. Also we would question the need for the small rear windows and black panels. The current VW Multivan is obtainable with only front side windows, so perhaps the T5 will also have this option.

Campervanning is no longer a warm season occupation, we use ours throughout the year and have slept in temperatures of -5 deg C without too much difficulty. We would plead for some basic considerations for winter use on any new van. Avoid long runs of external water pipe and also provide the water tank with foam insulation and possibly an immersion heater, these two items would enable any new conversion to be used 90% of the time.

Finally, can I just say that my current Topaz is 5.065m long and 2.54m high. Most ferry operators surcharge campervans above 5m in length and above 1.8m and 2.5m in height at £10.00 per crossing. So for each trip to France we make the surcharge is £30.00, ie. £60.00 per trip. Three trips per year = £180.00 per annum. A-S can do nothing with the length, as that is a VW factor, but by saving 40mm in height we could be saving £60.00 per annum. Just a thought.

Anne & Arnold Penney

Having "lost" a roof light when travelling down to Devizes we can sympathise with *Anne & Arnold's* comment. However, it had lasted for over 10 years and the other two are still O.K. So we think it must have been "just one of those things!"

-----oooOOOooo-----

Leaks (1)

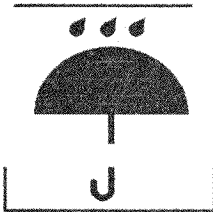

I have encountered a problem with my 1997 Amethyst with which I hope someone can help me. There is water ingress in the shower/toilet compartment via the light fitting. The water in the cover has, I think, fused the light which now doesn't work.

Is it a poor seal on the ladder mounting which is causing the problem or is there something else? Any help will be gratefully appreciated.

John Ward

-----oooOOOooo-----

Leaks (2)

With reference to *Roger Mason's* comments in the March Newsletter. This was certainly not an isolated problem. I wrote to the Newsletter at the time of the same problem with the installation in my February 1994 Clubman VW / T4. My wet carpet was eventually traced to the Cascade and came from the hot and cold spigot connections which were smooth. Having replaced them with 'barbed' spigots, assembled with a smear of Seelastick, I have had no further problems.

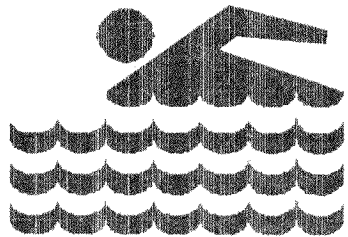

APRIL 2003

RALLY SUPPLEMENT

May I remind you that, unless otherwise stated in the Rally Supplement, all rallies are applied for by posting a rally slip, with a cheque for the appropriate amount, to the rally marshal. Unless otherwise stated ALL rallies start at 12 noon. Please do not arrive early. If you are unable to attend a rally inform the marshal as they may be able to allow another member to take your place.

Will Marshals please send me the rally information for this Supplement at least three months before the date of the rally.

NEW RALLY 12th - 14th September. Ludlow Food & Drink Festival

MARSHALS REQUIRED for the following Show. Contact the Rally Co-ordinator if interested.

18th - 20th. *July. Midsummer Music & Leisure Show, Lincoln Racecourse.*

**NEW. 4th - 8th April (4 nights) Long Hazel International C & C
Park, Sparkford, Somerset.**

Emergency Tel.No. 07714550731. Marshals' mobile 8 -10am & 6 -10pm.

Rally Marshals: Barbara & Alan Potter.

Site Fee: £7.00 per night. Electricity: £2.00 per night. Rally Fee: £2.35 all incl VAT.

Rally slips to: Mr & Mrs A Potter, Westbrook, Mill Lane, Monks Risborough,
Bucks HP27 9LG. Tel: 01844 274 821. Cheques payable to: Mrs. B. A. Potter.

Attractions: Within easy reach: Yeovilton Fleece, Air Arm Museum, Sherborne Abbey & Castle, N.T. properties & gardens. Walking distance to Haynes Motor Museum.

Directions: Situated 8 miles north of Yeovil, just off the main London to Penzance trunk road, 400 yards from the new roundabout at the end of the Sparkford by-pass (A303) on old road into the village.

NEW. 4th-8th.April (4 nights). Peak Rail,Rowsley South Station, Nr. Matlock,Derbyshire.

Emergency Tel.No. 07939 288586 (Marshal's mobile).

Rally Marshals: Jeanne & Mike Hall.

Site Fee:£4.70 per van per night.Rally Fee £1.20 per person (both incl.VAT).

Water & Elsan disposal. GREEN FIELD site but toilets open during station hours.

There are two electrical hook up for people who have a special need.

Booking slips & cheques to Mike & Jeanne Hall,45 Nottingham Road,Belper, Derbyshire.DE56 1JG. Cheques payable to M.T.Hall. Tel.No.01773824565.

Attractions: In the picturesque picnic area of this enthusiasts steam railway, beside the River Derwent with miles of walks. 10% off all-day tickets for steam trains to Matlock £6.00 adults,£4.50 seniors to ride all day or spend time in Matlock. Within the Derwent Valley World Heritage Site & the Peak National Park. Nearby are Chatsworth House,Haddon Hall,Carriage Museum & Bakewell's famous Market on Mondays.Buses to Sheffield,Matlock,Bakewell,Stockport & Manchester.

Directions: 3.9 miles north of Matlock(Bakewell directions) on the A6. Going north turn **left** on to Harrison Way,just after Shalilmar Restaurant & follow Peak Rail signs.

10th- 13th.April (3 nights).Ackworth Cricket Club,Nr.Pontefract,W. Yorks.

Emergency Tel.No.01977 612 773. Rally marshal's home No. will check for messages.

Rally Marshal: Alan Guest.

Site Fee:£3.00 per night. NO ELECTRICITY. Rally Fee:£1.75 couples,£1.20 singles.(Incl.VAT).Cheques & Rally slips to Alan Guest,27 Chiltern

Drive,Ackworth,Pontefract,West Yorks. WF7 7DW. Tel.No. 01977 612773.

Attractions:Pontefract 2 miles, Nostell Priory 2 miles.Bus stop nearby with cheap fares to local towns.

Fish & Chips plus a pub that serves breakfast for £3.00 and other food.

Directions:A638 side of Boot & Shoe,Ackworth Cricket Club. ½ Mile from roundabout A638 to Wakefield.

24th-26th.April.National Motorhome Show,Peterborough.

Emergency Tel.No. 07714 091 349 (Marshals' mobile on 8.00-10.00 am & pm).

Rally Marshals:Pauline & Neil Rogers,Evelyn & Ben Mansfield & Jean & Ian Sellers.

Please note that ALL booking forms *MUST* have been returned to Warners the organisers by Friday 28th.March if you wished to rally with the Club.

The rally finishes at 12 noon Sunday but you may remain on site until 12 noon Monday.

*****Then you must also complete a Club rally slip and return it, with the Rally Fee of £1.75 couples, £1.20 singles (both inclusive of VAT) to: N.C. & P. Rogers, 3 Appleby Close, Aldbrough St. John, Richmond, North Yorks. DL11 7TT. Tel. No. 01325 374 540 Cheques payable to N.C. & P. Rogers. Please collect the Club rally information pack from the Club marshals before parking.**

If you book using the special Club fees then you *must* rally with the Club.

No arrivals before 2.00p.m. Thursday.

2nd - 5th .May (3 nights) A.G.M. Newark Showground, Notts.

Booking form in the February Newsletter. *Closing date for booking 29th .March.*

5th - 9th .May (4 nights) Walking the Wolds, Bilsby, Lincs.

Emergency Tel. No. 077 68 16 45 22.

Rally Marshals: Janet Sutterby & Eileen Kellard.

Site Fees: £14.00 for the rally. No Electricity. Rally Fee: £2.00 (incl. VAT) payable with booking slip to Janet Sutterby, 3 Bilsby Road, Alford, Lincs. LN13 9EW.

Tel. No. 01507 462449.

Venue lawn of old rectory Toilet & community room available. Quiet village, walking, cycling, relaxing, sea 6 miles. Walks will be arranged.

Directions: In east Lincolnshire take A16 Boston to Louth road, the A1104 to Alford and the A1111 to Bilsby (signed Sutton on Sea). Venue on the left almost opposite the village church.

Limited numbers.

8th - 11th .May (3 nights) Burn Gliding Club, Nr. Selby, North Yorks.

Club Tel. No. 01757 270 296 (Emergencies only).

Rally Marshal: Alan Guest.

Site Fee: £4.70 per night (incl. VAT) **No Electricity.** Rally Fee: £2.35 (incl. VAT) Booking slips to Alan Guest, 27 Chiltern Drive, Ackworth, Pontefract, West Yorks.

WF7 7DW. Tel. No. 01977 612 773. (after 6.30pm.) Cheques payable to A. Guest.

Attractions: Gliding trial flights/ lessons over weekend (subject to weather). There is a market in Selby on the Monday.

Directions: From M62 junct. 34 take A19 towards Selby, Gliding Club signposted in Burn Village.

9th - 11th May Thames Valley Caravan & Motorhome Show. NO MARSHAL

8th - 11th May (3 or 4 nights) Working Rally, Three Counties Showground, Malvern.

Rally Marshals: Dorothy & Baz Wellard. Tel. No. 01329 231 254.

DUE TO INSURANCE PROBLEMS THIS RALLY HAS HAD TO BE CANCELLED, AS HAVE THE OTHER WORKING RALLIES PLANNED FOR THIS YEAR.

9th - 12th May (3 nights) The Azalea & Rhododendron Rally. Exbury Gardens, Hants.

Emergency Tel. No. 07785 551229.

Rally Marshals: Mo & Mike Valentine.

Site Fees: £6.00 per night. No Electricity. Rally Fee: £2.50 (incl. VAT)

GREEN FIELD SITE, fresh water point and Elsan emptying hole in ground.

Approx 2 miles from Gardens - bring your bike.

Please send a rally slip & cheque payable to M. Valentine, 11 Hamilton Close, Langstone, Havant. PO9 1RP. Tel. No. 023 9248 2818.

Attractions: Exbury Gardens & Steam Railway, the New Forest, Historic Beaulieu, National Vehicle Museum. Views over the Solent and the Isle of Wight. Otter & Wildlife Conservation Park, Lymington, Southampton & much more.

Shops some 3-4 miles away.

Directions: From M3 join M27 westbound. Exit at junction 2 onto A326, signposted to Beaulieu Motor Museum. Continue straight over 6 roundabouts, at 7th roundabout turn **right** onto the B3054, signposted Exbury Gardens. At next junction, by Royal Oak pub, turn **left** then immediately **right**, signposted Exbury Gardens. After 2 ½ miles Gardens on **right**, continue on. At sharp left turn, go straight on - narrow road.

Approx. 1 mile turn **right** onto Gravel Road - Field on **left** in 150 yds.

DOGS ON LEADS AT ALL TIMES.

LIMIT OF 30 VANS.

15th - 19th May (4 nights) Little Cotton C.P., Dartmouth, Devon.

Emergency Tel. No. 01803 833 675. (Site owner)

Rally marshals: Pam & Terry Holtom assisted by Jenny & Geoff Raistrick.

Booking slips and cheques payable to Terry Holtom, 8 Courtlands Road, Torquay, Devon. TQ2 6JR. Tel. No. 01803 612669.

RALLY FULL.

NEW Date 30th. May – 1st. June. (2 nights) Blue Lias, Nr. Coventry,Warks.

Emergency Tel.No. 07799660641.Marshals' mobile.

Rally Marshals: Sandra & Bernie Wisely.

Site Fees: £5.85 per night. NO ELECTRICITY. Rally Fee:£2.35 (Both incl VAT)
GREENFIELD SITE.

Cheques & rally slips to Sandra Wisely,2 Mount Pleasant,Bishops Itchington,
Southam,Warwickshire.CV47 2QE. Tel.No. 01926 614 194

Fishing available on site –a permit can be purchased on site @£5.00 per person.

Meal available on Saturday night £5.95 per head payable to site.

Choose from: Steak & Ale Pie, Plaice or Vegetable Lasagne.

Choice of boiled/ chipped potatoes - please state your choice + vegetables of the day.

Directions:From the Southam By-pass take the A426 signed Rugby.In just over 1
mile at the first cross road turn left (un-classified road 17tgw)Blue Lias is on the *left*
in about ½ mile.

From Rugby take the A426, go through Dunchurch towards Southam.After approx.
4 ½ miles pass the Boat Inn Public House on the right.At just under 1 mile at the next
crossroads turn *right* (un-classified road 17 tgw).Blue Lias is on the *left* in about
½ mile.

Maximum of 20 vans.

NEW 6th. – 8th. June (2 nights). Gryphon School,Sherborne,Dorset.

Emergency Tel.No. 07788 968504 (Marshal's mobile).

Rally Marshals: Eirwen & Ben Cox & Dorothy & Baz Wellard.

Site Fee:£4.50 per night incl.VAT NO ELECTRICITY Rally Fee:£2.00 incl.VAT

**All sites are hardstanding but blocks needed.

Please send a completed rally slip & cheque payable to Mrs.E.Cox,Tan y Graig,
8 Quarr Lane Park,Sherborne,Dorset.DT9 4JB.Tel.No. 01935 815960.

Attractions: Sherborne is a very architecturally attractive town,only a few minutes
walk from the site.Other attractions are Sherborne Castles (2) & grounds,Sherborne
Abbey, a small Saturday market.Lovely Dorset villages with good pub food in
immediate area ,and a beautiful beach at West Bay (45 mins. drive).

Please indicate if interested in a Fish & Chip Supper on Saturday.

Dogs welcome (**on lead at ALL times**) but must be exercised **OFF SITE**.

Directions:From the East, Salisbury A30 to Sherborne.From West M5,A30 to
Sherborne.At traffic lights in Sherborne take B3145 to Wincanton.In about ¼ mile
Gryphon School on **right**.

PLEASE DO NOT ARRIVE BEFORE 5.00 p.m. Limit of 25 vans.

8TH. - 15th. June.(7 Nights Sun.-Sun).Delftse Hout Caravan Site,Delft,Holland.

Rally marshals:Tricia & Ted Pratt & Jan & Vic Hicklin.

Tel.No.01283 538 818. **THIS RALLY IS NOW FULL.**

17th - 20th June (3 nights). Hoddom Castle Caravan Park, Nr. Lockerbie, Scotland.

Emergency Tel.No. 07790183780 (Marshal's mobile).

Rally Marshals: Moira & Allan Blackstock, Pat Holland & Noel Bonner.

Site Fee: £7.23 per unit per night. Electricity: £1.70 per unit per night. Rally Fee: £1.75 per person, all include VAT.

Rally slips & cheques to: A & M Blackstock, 39 Sumpter Croft, Penwortham, Preston. PR1 9UJ. Tel.No. 01772 749 178.

Site has large toilet/shower block, bar, restaurant, golf, tennis, mountain bike trail. BBQ area and dog exercise area, all set in a well wooded estate.

Places of historical interest, good shopping, Solway coast & Scottish borders all within easy driving distance.

Ranger booked for a guided walk. Possibility of evening meal/takeaway. Room booked for evenings.

Directions: From A74(M) take junction 19 at Ecclefechan. At the roundabout turn *left* into the village and turn *right* at the church on B725 (Dalton) road. Turn *left* at T-junction and over Hoddom Bridge the entrance to Hoddom Castle Caravan Park is on the *right*.

19th June - 3rd July (14 nights). Sarzeau, South Brittany, France.

Rally Marshals: Dorothy & Baz Wellard Tel.No 01329 231 254, assisted by May & Derek Armitage & Brian Thomas. **THIS RALLY IS NOW FULL.**

If you wish to organise a rally in 2003 then please contact me as soon as possible to enable me to advertise the rally in this supplement.

We depend on volunteers within the Club to act as rally Marshals.

If you know of a suitable site why not think about running a rally.

It is not difficult and help is available. It is important that all potential rally dates and venues are checked with me first as, unless they are approved by the Club, there will be no Public Liability Insurance.

Neil C. Rogers

3 Appleby Close,

Aldbrough St. John,

Richmond,

North Yorks,

DL11 7TT.

Tel./Fax. No. 01325 374 540

E-Mail. ncr@nasuwt.net

Local assistant: Jerry Haxton (01483 223 476) Woking, Surrey.

E & O E

Rally : Date:

Your name and address(Please PRINT)

Post code:

Phone No.: Van Reg:

Membership No: Day/Time of arrival:

In the event of an emergency at the rally whom should we contact?

Name Phone No.

Please complete both sides of the form!

.....

Rally : Date:

Your name and address(Please PRINT)

Post code:

Phone No.: Van Reg:

Membership No: Day/Time of arrival:

In the event of an emergency at the rally whom should we contact?

Name Phone No.

Please complete both sides of the form!

.....

Rally : Date:

Your name and address(Please PRINT)

Post code:

Phone No.: Van Reg:

Membership No: Day/Time of arrival:

In the event of an emergency at the rally whom should we contact?

Name Phone No.

Please complete both sides of the form!

+Is this your first ASOC rally? Please tick box. Yes No
Number of people in your van: Adults..... Children.....

Names of Adults

Names of Children (including ages)

Extras: Please indicate which you would like, if available:

Electricity: Yes No Evening meal: Yes No

Have you any special needs? Yes No If Yes please specify:-

Full payment MUST accompany this slip-cheques payable to the marshal.

POST FORM TO REACH MARSHAL 14 DAYS BEFORE EVENT,IF POSSIBLE PLEASE!

Is this your first ASOC rally? Please tick box. Yes No
Number of people in your van: Adults..... Children.....

Names of Adults

Names of Children (including ages)

Extras: Please indicate which you would like, if available:

Electricity: Yes No Evening meal: Yes No

Have you any special needs? Yes No If Yes please specify:-

Full payment MUST accompany this slip-cheques payable to the marshal.

POST FORM TO REACH MARSHAL 14 DAYS BEFORE EVENT,IF POSSIBLE PLEASE!

Is this your first ASOC rally? Please tick box. Yes No
Number of people in your van: Adults..... Children.....

Names of Adults

Names of Children (including ages)

Extras: Please indicate which you would like, if available

Electricity: Yes No Evening meal if arranged: Yes No

Have you any special needs? Yes No If Yes please specify:-

Full payment MUST accompany this slip-cheques payable to the marshal.

POST FORM TO REACH MARSHAL 14 DAYS BEFORE EVENT,IF POSSIBLE PLEASE

Shortly afterwards I fitted 2 isolating taps into the supply and return pipes - obtained from C.A.K. Tanks of Kenilworth (019 2685 4271). This also involved short lengths of red and blue hose, with the appropriate barbed unions in order to provide accessibility from the internal flap. The Cascade no longer fills automatically when the isolating taps are turned off. Be very careful to avoid damage to the insulating cover of the Cascade and ensure the DIN plug on the Cascade is inserted before replacing the bed. If more information is required please phone 013 2389 6390. It is a time consuming but low cost D.I.Y. Job.

Gordon Finlayson

-----oooOOOooo-----

Leaks (3)

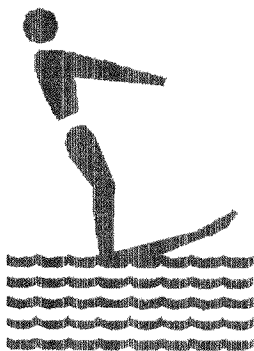

We have had a similar experience (like *Roger Mason* and the Editor) to that described in the March Newsletter about the Cascade water heater, both in a previous caravan and in our present nine year old Clubman. Fractured plastic fittings and both front and rear of the unit. The leak causing wet carpet just behind the driver's seat by the leisure battery from the rear fitting. Earlier in 2002 we had a leak from the fitting by the drain plug, which was replaced. A visit to Willersey sorted the problem out.

My advice is that if either the front or rear plastic fitting leaks replace both by taking the whole unit out. To withstand the large variations of temperature requires the brightest specification plastic. I consider the heater as an unreliable unit in either motorhomes or trailer caravans.

Help, please

Spring cleaning is upon us, so curtains have to be cleaned. Removal of curtains for cleaning is part of this job. It occurs to us that motorhome designers consider that, like ashtrays when they are full, you should change the vehicle when curtains need to be cleaned!

Front curtains in the cab are little problem except that they are fiddly. The side curtains are a real problem because the access to them is behind the deep fixed pelmets. Replacement is twice as bad as removal. Miniature nylon runners into small aluminium channel! 70 year olds are expected to be contortionists, half hanging out of the side

windows is not on. Tiny metal retaining blocks dropping behind upholstery also do not help.

We haven't found out yet how to remove the end curtains at the kitchen end. The two curtains are on a one piece channel with no entry at either end. They appear to have been fitted first and the permanent fitted pelmet afterwards. An appeal to Willersey did not help!

Vera and Bob Hewitt

I seem to remember that one of our members, a long time ago, decided that as they used the blinds and did not draw the curtains they got round the rear curtain problem. Somehow they removed the curtains and the rail and then fastened some Velcro up behind the pelmet. The curtains were neatly gathered across the top and had Velcro sewn to them so that it became a simple matter to pull them down, wash them without disturbing the Velcro, and replacing them. So far as the side curtains are concerned, perhaps we are supposed to remove the windows first! Any (much more) sensible suggestions, please?

-----oooOOOooo-----
Advice Requested

After 6 years of caravanning we have recently swapped car and caravan for a Symbol. There are a number of questions which we hope members will be able to answer.

1. Any tips on packing? Which items are best stored where, e.g. bread?
2. How do you stop the carpet getting dirty? In our caravan we put runners over the carpet, but the table socket on the floor and the moving bed legs prevent this in the Symbol.
3. To save carrying a separate table for use outside, can we obtain a folding foot into which the table leg and top fits?
4. What are the correct tyre pressures? I cannot find anything in the handbook.
5. Do different tyre pressures apply when towing a small trailer or using our Pendle towbar mounted cycle rack.
6. We have had a Witter towbar with a half step fitted by Chester Towbar and Trailer Centre (good advice and service). The half step enables the electric socket to be fitted on the other side, thereby providing more ground clearance. Does anyone want the original A-S rear step?
7. How do we stop the upholstery and woodwork fading from sun coming in through the windows while the van is parked up?

8. We have a spare set of interior window screens. Any offers for them?

Our telephone number is 019 2873 3739.

Colin Kennington

The answer to question 3 is a definite "Yes". We have a tripod base which can be obtained from most caravan accessory dealers into which the table leg fits. We also have a shorter leg for outside "coffee table" type use instead of the longer one we use inside the van. Question 4 raises an old question yet again. The best answer is to weigh the van, loaded for travel, preferably with separate weights for front and rear axles. Then consult the tyre manufacturer giving those weights and you should then obtain the advised pressures. It seems a little obvious, in answer to question 5, that additional weight on the rear of the vehicle for any reason would presumably require an increase in tyre pressure.

For the rest of the questions - members - the floor is yours!

====oooOOOooo====

From the Factory

NEC Review

So the NEC's National Boat, Caravan and Outdoor Show is over for another year. Everyone at the factory would like to say a big "thank you" to all ASOC members who helped man the Auto-Sleepers stand and also to those who visited the stand.

Auto-Sleepers had a great show with sales being well beyond predicted figures. The new and upgraded vehicles introduced were a huge success. The Nuevo ES, a new 4-berth vehicle, with two forward facing seats in the rear, was very well received throughout the industry. But most importantly it was even better received by the public - so much so that the first vehicle was sold on the opening day of the show.

In addition to this, the upgraded Auto-Sleepers Monocoques, the Peugeot Executive GLS and Talisman GLS were also very much in demand. These vehicles are have been reduced in price but significantly improved in specification and value - and they now include a number of extras as standard - including 3 metre awning, full oven and grill with 3 gas burners and an electric hot plate, refrigerator with full width freezer, winterised fresh water tank, extractor fan in the kitchen and remote sensor for Truma heating system.

Another buzzing area of the stand was around the new Luxor. The Auto-Sleepers A-Class Luxor EK was also on display for the first time. This luxurious and spacious vehicle, a new addition to the superior Luxor

range, boasts an end kitchen - giving an ever increasing choice of vehicles to suit our customers' different requirements.

And those different requirements will continue to grow. Our statistics also showed that a large percentage of Auto-Sleeper buyers at the NEC show were first time buyers, suggesting that more and more people are realising the joys of the motorcaravanning lifestyle. So watch out for new members of the ASOC - the word is obviously spreading! Thanks again for all the support from Owners' Club members over the course of the show! Same time next year?

Anna King

-----oooOOOOooo-----

Toilet Cubicle Doors

Do you have problems with your toilet cubicle door? Does it swing open and/or rattle while you are on the move? I have had problems with mine & adjusting the door catch has improved the situation but, on the odd occasion especially over bumpy surfaces, the door sometimes springs open.

When my wife and I visited the National Boat, Caravan and Outdoor Show at the NEC in February, we looked at the new range of A-S vans and we noticed that on the toilet cubicle door an improved type of lock had been fitted (someone else has had problems like me!). The lock was of the same basic type and size as we have fitted on our Legend but from the lock mechanism inside the door two rods were fitted, one going upwards and one downwards. At the end of each was a hook (at right angles to the rod). When the door button was pushed, the lock operated as normal, but the rods and hooks turned through 90 degrees. The hooks, in turning, hooked round a pillar fitted inside the door frame at the top and bottom. The system was so simple, all the problems of doors springing open and rattles were solved in one go.

This decided us to seek out a supplier and one was soon found at the show. For those interested they are: CAK Tanks Ltd, 10 Princes Drive Ind. Est., Kenilworth, Warwickshire, CV8 2FD. Tel:- 019 2685 4271.

They did not have this type of lock at the show, but they provided me with an excellent catalogue and showed me the items I required. For those interested the items are on page 23 of their catalogue. The parts required are:

1. FPLDD Double Sided Button Lock. Gold outside, Brown inside £8.50
2. FPLHRB 'Hook Rod Set 2 x 1000mm. Brown Sleeve £4.10

3. Post & Packing

£4.40

Total

£17.00

The following day I ordered the parts required over the phone, delivery was quoted at 7-10 days, and delivery was within the time specified.

The only problem was that there were no fitting instructions. I had an advantage, as I had seen one in situ and I am a keen DIYer to boot! So it did not take long to fit. What did take most of the time was making the two hard wood blocks to mount the two pillars on. If anyone feels this is for them, the drawings I have made should help. The design I have made, should not be far out for most A-S motorhomes, Fig 1 for the top fitting Fig 2 for the lower fitting. The hook assemblies come as a pair, top and bottom, the rest are universal parts. The rods have to be cut to length, the upper rod will be longer than the lower rod. The rods go in to a depth of 8mm in the lock and 25mm into the hook assembly, so allow this when cutting the rod.

Best of luck.

Robin Gardner

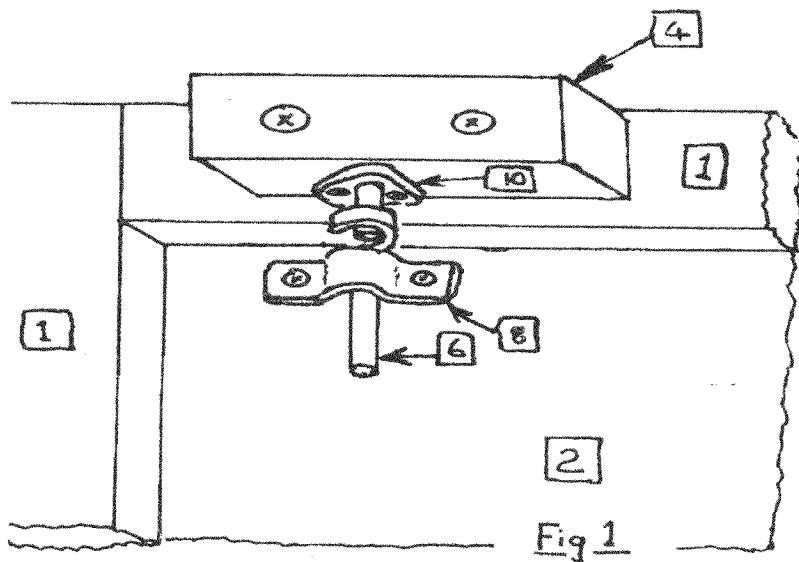

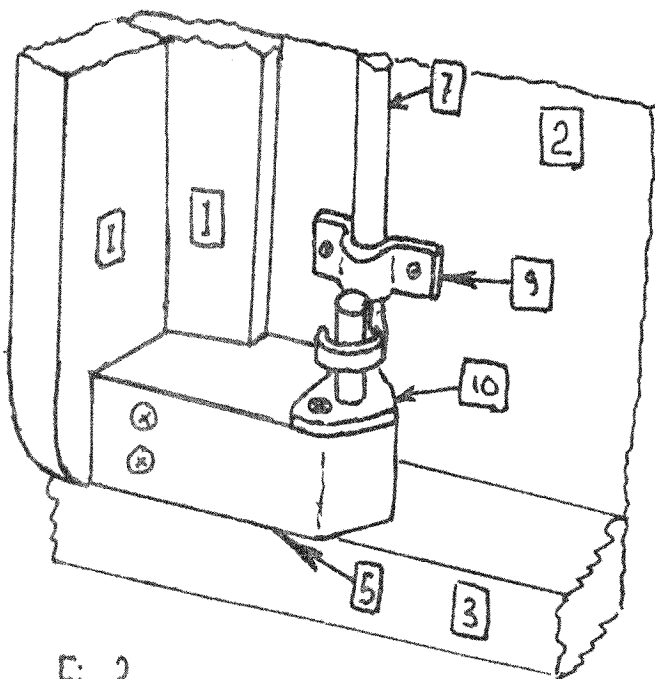

Fig 2

Key to Drawings

1. Door Frame
2. Door
3. Door Sill
4. Door Block, Upper *
5. Door Block, Lower *
6. Actuating Rod, Upper
7. Actuating Rod, Lower
8. Hook Assembly, Upper
9. Hook Assembly, Lower
10. Pillar Brackets, Upper and Lower

* To be made to suit your own Motorhome.



For Sale

VW Trooper, 1998. 1900 turbo diesel, 62,000 miles, F.S.H. Blown air heating, Fiamma bike rack. One year's MOT, taxed until November. Excellent condition. One owner, no animals, no children. £14,000.00 ono. Tel: Duncan

MacKenzie on 017 9220 2547 (Swansea) or 014 5477 8106 (Bristol).
Thanks for the donation.

#####

Topaz, 2.5 petrol, 'R' reg (1998), automatic. 15,000 miles, P.A.S., F.S.H., MOT March 2004; bike rack; Fiamma awning; battery mate; Silver Screens. One owner, non-smoker. Excellent condition. Tel: Jean & Alan Sudron on 013 7964 3142 (Diss, Norfolk).

Thanks for the donation.

#####

2 Brompton folding bicycles and extras. V.G.C. £150.00 each. Could be seen at AGM Rally or Club & Company Rally. Please ring Janet Sutterby or Eileen Kellard on 015 0746 2449. (Alford, Lincs).

Thanks for the donation.

#####

Two Dahon folding bicycles, colour graphite, 5 speed gears, 16inch wheels with new tyres and dynamo lighting. Complete with carrying bags. Cost new £300.00 +. Will accept £300.00 for the two or £160.00 each. Also a two ring mains electric hotplate, as new. £15.00. Contact Neil Rogers on 013 2537 4540. E-mail details and address in Rally Supplement.

Thanks for the donation.

#####

Peugeot Pollensa, 1.9 turbo diesel. September 2000, 7,800 miles. One owner. Immaculate condition. Fiamma awning, captain's seat, armrests, Status TV aerial, blown air heating plus convector, Sigma Thatcham cat 1 alarm, Gas/electric water heating. F.S.H. Non smokers, no pets, no

children. £24,995.00. Phone James Edmondson on 014 2527 8794 (Christchurch, Dorset). Thanks for the donation.

#####



Ford Amethyst, Diesel, 'R' (1997). MOT to July 2003. F.S.H. Mileage approx 23,300 only. Bike rack, side awning. A.1 condition, little used recently due to ill health which forces sale. £26,995.00 ovno. Vehicle is at Welwyn Garden City. Please telephone Brett Rowley on 020 8500 9025 (day) 01 9926 8136 (evenings) or 07 730 073 996 (mobile) or e-mail: brett@hogbitz.com

#####

RAVENNA, 'W' reg 2000, Boxer 2 litre petrol, 21000 miles, alarmed, awning, deadlocks, undersealed, many extras. Non-smokers, no pets. £22,950. Phone Doug Winfindale on 012 8321 1725. (Swadlincote, Derbyshire.)

#####

DUETTO 2.5 TURBO DIESEL. 1997 35,000 miles. One owner, immaculate condition, full service history and handbooks. Taxed, MOT. Thatcham Cat 1 Alarm with central locking, electric windows, PAS, Status aerial, gas bottles/regulator, Silver Screens, A-S crockery. Full A-S specification. Many extras. No pets or smokers. Genuine reason for sale. £19,995.00 ono. Phone Dave Bull 01189 611853 or email: DavidBull@NTLWorld.com

#####

2000 (W) Amethyst 2/4 berth Transit, 2.5 turbo diesel, PAS. One owner from new. 10,000 miles only. Non smokers. Status TV aerial, alarm, 2 bike rack, electric step, rear stabilisers, CD/radio, fog and spotlights added. Original A-S crockery and full A-S specification. All handbooks and service history. £28,750.00 ovno. Tel: David Codling on 012 0260 1217 or e-mail: davidcodling@yahoo.co.uk (Broadstone, Dorset). Thanks for the donation

#####



Talisman GL, 2000cc petrol. 'K' reg. 25,000 miles. 4 berth. Alarm, Silver Screens, Omnistor awning. 12 months MOT. Non smokers, no pets. Excellent condition. Reluctant sale due to ill health. £25,000.00. Tel: Sally & Don Gale on 0121 706 3521 (Solihull).

Thanks for the donation.

#####

Harrison awning de luxe model. Cost £500.00. Brand new, still boxed. £400.00 ono. Tel: D Cadman on 017 8228 9109 (daytime) or 017 8250 3030 (evening) - (Stoke on Trent).

#####

Harmony, Talbot Express 2.5 litre turbo diesel. 1990 'H' reg. 65,000 miles. Good condition. Alarm, Fiamma awning, Bike rack, Hitch, TV aerial and all the usual A-S refinements. MOT will be done at the end of March. £9,500.00 ono. Phone Glyn Evans, on 016 7256 3175 (Pewsey, Wilts) or e-mail him: gmevansavondale@care4free.net .

Thanks for the donation.

#####

VW Medallion, 2.5 TDI, 'W' reg (June 2000). 2 year warranty. 13,500 miles. 4 berth, 4 burner & oven, 3 way fridge, gas/electric blown air heater, Omnistor awning, Status aerial, Fiamma 4-cycle rack, extra 13 amp sockets, Silver Screens, Omnistep, Deadlock, security coded, P.A.S. F.S.H. Taxed. Non-smokers, no pets. Immaculate condition. Lovely motorhome, reluctant sale. £29,995.00. Tel Dennis Leeson on 019 44738616 or 07 904 010 847 or e-mail: dennisleeson@msn.com (Malton, North Yorkshire).

Thanks for the donation.

#####

Fiamma Top Box. Ultra box size 2. 75kg max. 45" x 35" x 16" approx. £100.00. Telephone Alan Russell on 012 6841 7143 (Basildon, Essex).

Thanks for the donation.

#####

Contents

Window Problems.....	2	Leaks (3).....	11
Magic Carpet - part 2.....	3	Advice Requested.....	12
Chairman's Chat.....	4	From the Factory.....	13
PARISIAN AUTUMN.....	5	Toilet Cubicle Doors.....	14
TOPAZ OR NOT TO TOPAZ.....	8	For Sale.....	17
Leaks (1).....	10		
Leaks (2).....	10		

Committee Members

President	Charles Trevelyan	013 8685 3511
Chairman	Ray Whiley	016 0345 2593
Vice Chairman & Rally Co-ordinator	Neil Rogers	013 2537 4540
Secretary	Janet Sutterby	015 0746 2449
Treasurer	John Tidbury	012 3553 8593
Membership Secretary	Norma Caley	017 7263 2734
Minutes Secretary	Mike Hall	017 7382 4565
Chief Rally Marshal	Ben Mansfield	017 2336 9769
Chairman, AGM Sub-committee	Nora Venables	019 0233 2105
Chairman, Club & Company Sub committee	Andy Cavell	016 3520 1976
Regalia Officer & Chairman TIG Sub-committee	Andrew Entwistle	014 2284 3057
Press Officer	Brian Smith	014 8784 1786
Newsletter Editor	Harry Henthorne	020 8808 9112

Any item appearing in this Newsletter may be freely used by other publications. Please acknowledge both Author and Source

Items for the Newsletter **MUST** reach your Editor by the **TENTH** of the month. You may post them to 144 Devonshire Hill Lane, London, N17 7NH or E-mail to harry_henthorne@lineone.net. **PLEASE NOTE:** Any E-mail which has an attachment will **NOT** be opened. The Editor reserves the right to edit or omit items. Advertisements for items to be sold or wanted by members are published free of charge; however small donations to Club funds are appreciated and will be acknowledged. No guarantee can be given that any item will appear in the next, or any, issue of the Newsletter. Cheques should be made payable to "Auto-Sleeper Owners' Club" and NOT to 'ASOC' as the bank will not recognise this.

IMPORTANT: Contributions from Members are published in good faith in the hope that they will prove useful or interesting. All reasonable care has been taken to ensure accuracy but no modification or suggestion has been tested by the Company, the Club or your Editor. Therefore no warranties are expressed or implied nor indemnities given. You try them out at your own risk.
