

TENTH ANNIVERSARY YEAR

**AUTO-SLEEPER
OWNERS' CLUB**

1989 - 1999



**NEWSLETTER 130
JULY 1999**

Hello.

I am trying to get most of this issue ready for the printer before *Sheila and I* go on holiday. We hope to be back, at the latest, by Monday, 21st June which won't give me much time to finalise the print and post it off. But knowing our friendly printer, I am sure that he will do his usual tricks and get things out to you in time.

====ooo000ooo====

Photographic Competition

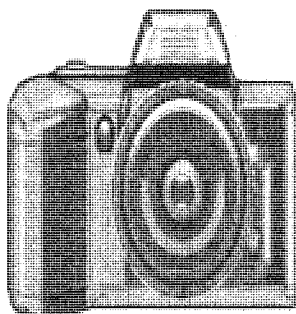

This has often been associated with the Club and Company Rally but this year your committee has decided that **September 15th** will be the closing date for entries. Cash prizes are offered to the winner and a couple of runners up. Send your entries, **prints only please**, to our Press Officer, *Mrs Pam Davies*, 4 Southbrook Road, Havant, Hampshire, PO9 1RN.

====ooo000ooo====

HELP !

We have a Trophy. We also have (or had) a mouse (or mice). We have a smell (or smells) too. **WE HAVE A PROBLEM!** We found signs while packing for Kettering, the van not having been used for overnights since mid-December. In the absence of food it had nibbled a cake of soap. No wonder it had diarrhoea. After sorting that out we set off in high hopes that we had no uninvited passengers and all went well until towards the end of the weekend: "That new loo stuff isn't very good." - "Is the gas really turned off?" - "Oh No....."

Smell lingered on in the kitchen area after we returned. *Colin* removed the backs of all the floor-level cupboards and, with torch and mirror plus contortions to rival Houdini, inspected as many of the crevices and holes as possible. What a lot there are back there. All to no avail and the only further signs we found were

nesting materials in one of his trainers. It didn't help that *Colin* has lost most of his sense of smell, so only half believed all this fuss and had to call on *Margo's* nose at intervals.

Said smell gradually faded and we thought that all was well until we had been underway for about half an hour last weekend. The smell gradually made itself noticeable by the front passenger seat. More torch and mirror work round the engine and exhaust. Smell goes if van is left standing with ventilation. One sets out hopefully, only for it to re-occur in about a quarter of an hour. We are stumped! Any ideas? We hope that the problem will have solved itself by the time this appears in print. After all, skeletons don't have much smell! But we can hardly be the only ones who have suffered from this 'delicate' complaint. Any suggestions welcome, especially ideas about stopping it from happening again next winter.

Margo & Colin Lumb

The two little tiggers (puss cats if you haven't seen them) who travel in our van chase mice! Well, cats do, don't they? So we don't have any problem. Perhaps the Club's Tiggers can help.

====oooOOOooo====

Unleaded Petrol

The question from *Elaine Whitfield* has brought a number of responses which I shall try to summarise.

Mick Holland advises that the VW/Audi engine code, stamped on the top of the crankcase, should be checked. 1.9 litre engines, August 82 onwards, with the code of 'DF' or 'DG' can be run on either unleaded regular or unleaded premium fuel. Code letters 'DJ' mean that the ignition should be retarded and they can then use unleaded premium fuel only.

Matthew Byng bought a 1986 Trident in January. Before buying he checked with a dealer and a specialist repair centre and both assured him that the standard VW 2 litre engine could run either on lead free or four star. He had it tuned to unleaded and has run for five months without incident. He would appreciate advice as to whether he is in danger of causing long term damage.

Maurice Wright has a Harmony which has "responded beautifully" to Broquettes. No modifications were needed and she runs happily on unleaded. The address is Roadnet, Bluebird House, Povey Cross Road, Horley, Surrey, RH6 0AF and the telephone number is 0129 377 5454 and the cost is approximately £50.00. Apparently the Broquettes are fitted, the vehicle is run on one tankful of 4 star and then transfer to unleaded. Apparently this idea was designed and used to enable the Merlin aero engines to operate on low grade Russian fuel during WW II. This company also supply a device called "System Four" which was mentioned by David Jones. He gives the telephone number as 0700 078 3855 and says that in fitting it first to a 1986 Volvo 760 Turbo car he got an immediate improvement in fuel consumption from 18 mpg to 25 mpg. That car has now covered 15,000 miles using unleaded fuel with no ill effects. He has also fitted a unit to his current car, a Renault 2.5 Turbo Diesel and again has improved fuel consumption.

Barry Crawshaw has just received product details of Millers VSP Plus (lead substitute and octane booster). This is a liquid for adding to unleaded (95 octane) fuel and it is claimed to protect against valve seat recession, increase the octane rating to 4 star values, maintain engine performance without need for retuning, prevent pinking and reduce CO and hydrocarbon emissions. Millers Oils Limited, Brighouse, West Yorkshire, HD6 3DP - telephone 0148 471 3201.

Finally, the gentleman who prints our Newsletter, Mick Hughes, is a distributor for Amway Corporation who supply a fuel additive. This apparently does all the things which Millers VSP does and can be used in diesel engines where it boosts the cetane number. Amway also manufacture other items for car care. Further details can be obtained from Mick on 0120 346 0739 which is in Tile Hill, Coventry. It is his home number so you may have to leave a message.

-----000000000-----

Kipper Problems

In reply to *Harry Warren's* letter this may be helpful. I have the same problem. I 'revolve' with the consequence of becoming knotted in my pyjamas. The problem was solved - the knotting that is - by wearing nylon pyjamas which allow me to turn or slide over without the inherent problems experienced by *Harry*. Such pyjamas can be purchased from Celic Ltd, telephone 0123 435 4811 but the material they use is thin - nearly see through. So don't stand in a doorway with the light behind you. If anyone knows of a good quality material I should like to know.

Rolf Payne

====000000000====

Don't be a Kipper - be a Sardine

That's our advice to *Harry Warren*. Unzip your sleeping bag and put it in a single duvet cover, Get your wife to put her sleeping bag into another cover, A single blanket can anchor the bottom of the bed and be useful at chilly times of the year. You can "change the bed" by sleeping on the other side of the "duvet" and carry a spare cover. A thin double sheet is sufficient cover on hot nights. The sleeping bags will seldom need laundering.

Margaret & Eric Thornton

====000000000====

Taming the Crocodile

Regarding *Jim Andrews* letter, we tamed the crocodile by sticking a pair of those self-adhesive Velcro discs on the back panel and lid to mate up when the lid is open. They can be purchased from camping and caravanning accessory shops and are called "Velcro Coins".

Hazel & Geoff Whatley

Similar advice was given by *Harry Mackley* and a letter from *Maurice Wright* suggests that *Jim* sits down and saves the problem!

#####

Falling Thetford lids seem to be a 'National Problem'. Our solution was to use a clip like the one fitted by A-S to hold up the sink cover. Once in place it is neat, holds one or both lids and

matches the colour scheme. Efficient and very cost effective.

Diana & Keith Rhodes

Is that what is meant by a crocodile clip?

====ooo000ooo=====

CLUB & COMPANY RALLY, THREE COUNTIES SHOWGROUND, MALVERN 23 - 25 JULY 99

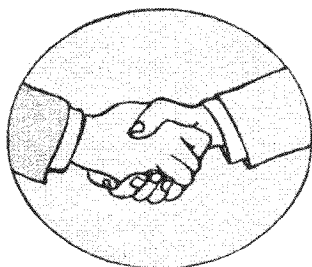

For those who have yet to book for this prestigious occasion may I take the opportunity to remind you that *Jackie Claxton* will be closing her books on the 9th July. Any queries - but not bookings - after that date to me, please - 0132 923 1259. Late entries will be payable on the gate, with a premium of £10.00. You will be asked for your name, current membership card and registration number- for insurance and accounting purposes. Pay by cheque please. Entry will be by the Yellow gate which will close at 2200. The Brown gate will not be open until 0800 on Saturday for day visitors (which precludes any overnight camping on Friday night).

This year's charity, as you will be aware, is LUPUS and to support this worthwhile cause we will be having a raffle (run by *Stella Ross & Dorothy Wellard*) and the valuable assistance of members to run charity stalls. Could you please support these volunteers as much as possible by bringing along donations and perhaps helping on their stalls for short periods:

- *Sheila Henthorne* - books (**not magazines please**)
- *June & Brian Metcalfe* - any bottles/jars (full !)
- *Margo & Colin Lumb* - bric-a-brac
- *Carol Hooper* - cakes

We are hoping to show some of the 'classic' motorhomes produced by Auto-Sleepers. If anyone has an A-S (or old photographs) which they consider would fall into the 'classic' category (pre 1985) perhaps you could let me know.

Brian Hooton has now handed over to me in my role as Chairman, but has agreed to stay on the sub-committee for this year, along with *Eileen Kellard, John Cox and Ben Mansfield* - and to all I am very much indebted. Do come along to join in and take advantage of the extensive activities put on by your Club and the Company.

Baz Wellard

====ooo000ooo====

Carbon Monoxide and Tyre Failures

For the last 3 years I have been using the prior model to that mentioned in the May issue of the ASOC magazine. I was entirely satisfied with it and it was very easy to fit, being supplied with a cradle into which it slotted. Fortunately it has never been called upon to give warning of danger. The sensor/battery module needed replacing this year and the whole unit was replaced at module cost only, with the latest SF330KM model, which has been developed to comply with latest EU requirements. Unfortunately it no longer has the cradle and was not so easy to fix to a sloping wall in my AutoSleeper Executive. I have had to resort to a sticky fixer to stop it swinging about when on the move. SF Detection says they are aware of this drawback, but are bound by EU legislation. However, they are now developing a 12v/230v model specifically for the caravan and motorhome market, which will take account of my criticism. They expect it to be available in October this year at which time they may offer me an exchange.

Having read Brian Ramsden's description of his unfortunate incident, I take note that his tyre fortunately did not deflate. However, I think it an appropriate time to suggest a set of Tyron Bands for all 5 road wheels which cost about £250.00. Whilst they will not prevent the problem they will keep a deflated tyre attached to the rim and the vehicle upright in the event of a puncture, thus avoiding potential disaster. When, in 1992, we had a trailer caravan tyre failure at 60 mph on a French motorway, although the outfit jack-knifed, we stayed upright and lived to tell the story. They saved our lives and all four of our family vehicles now have them fitted.

Sean Hollands

====ooo000ooo====

Tyres

Members may be interested in a recent experience when I called into the garage to fill up. First I used the air line, the tyre pressures were spot on. Then I filled up with diesel and drove to the exit where a helpful motorist told me that I had a flat O/S/R tyre. I was in the middle of the exit so had to move. Fortunately there was a small lay-by fronting the garage that I was able to back into. I called the RAC who told me there was a 2 hour delay. I told them I was blocking the traffic (fib!) so they put me down as an emergency and turned up three quarters of an hour later. They pumped up the tyre and assured me that it was safe to drive on as I had only travelled 20 yards. The reason that the tyre had deflated was that the plastic valve extension core had stuck down, causing the air to leak out. A regular occurrence, apparently.

As I was driving to Kettering the next day (180 miles) I decided to have the tyre changed for the new spare, even though the tyre depot assured me it was perfectly OK to use. They also told me that Kleber 195.70 R15 is an excellent quality tyre, well up to the loads imposed by the T4 TDI Clubman. However, anyone using plastic valve extensions would be well advised when using an air line to check that the valve core has returned flush with the end of the extension.

Dennis Peel

-----000000000-----

More on Tyres

As a newcomer to the Club and reading my first Newsletter I was interested in the article headed "Catastrophic Tyre Failure". I too experienced a similar incident. I was driving our 'K' reg Clubman in February last year. We were on a dual carriageway at 55 mph and travelling light as we were not on holiday. The rear nearside tyre exploded and the vehicle ended up facing the wrong way in the outer lane. Luck was with us and no other vehicle was involved nor any injury to ourselves. What was left of the tyre had wrapped itself around the axle. The wheel was totally destroyed. The vehicle had done approx. 18,000 miles and the tyre was a Continental. I always check my tyre pressures before starting any

journey. As far as I could see my tyres were in perfect order. Attending police and AA could find no apparent reason for the failure.

The vehicle was bought second-hand so I cannot know how the tyres were treated beforehand. The vehicle was in extremely good condition on purchase. I did have one of those heavy rear bumpers which, on returning home, I immediately removed. I have also fitted all new tyres to a higher specification. I noted in the vehicle handbook that it is recommended that all tyres be replaced after five years. This April we purchased a Symbol and I shall watch my tyres like a hawk.

Bob Bastable

---==ooo000ooo===---

Vehicle Keys -continued

Peugeots are supplied with three keys; two black and one red. There is also a plastic card carrying code information necessary for emergency engine starts and the mechanical reproduction of the ignition keys. The black keys are coded at the factory and are those that should normally be used. The red key is the master and carries information programmed into the immobiliser. It is also used to programme or re-programme the two black keys. The red key should only be used by Peugeot dealers and should under no circumstances be used by either motorhome dealers or owners. Ignition keys (black) can be replaced up to seven times. Each time the new key must be programmed via the immobiliser by the red key. The red key is vitally important to the whole process and if lost cannot be replaced without replacing the immobiliser at a cost of approximately **£850.00** plus VAT. In the event of an ignition key (black) being lost it is advisable to replace this key and to enter the codes of the new key in the immobiliser's memory. This procedure will erase the code of the old key, making it impossible for anyone finding it to start the engine. I include a description of the system and the instructions for reprogramming the keys. For those of you who are feeling

particularly brave it might get you going when everything else has failed but my advice is that you don't try to do it yourselves, leave it to the professionals.

The system consists of the following components:

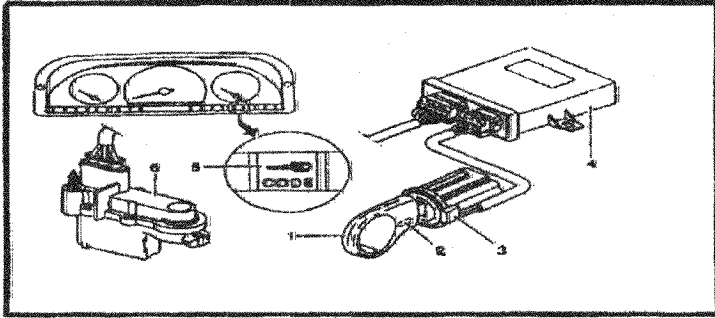

Note: The immobiliser system is supplemented by 2 components essential for service operations - 2 confidential code cards and a "MASTER" key (red).

Key

- 1,2. Ignition key with integral transponder (2)
3. Aerial integral with the original ignition switch
4. Central "CODES" unit
5. "CODE" warning lamp
6. Solenoid valve control module

Memorisation of the key codes in the central "codes" unit. The number of keys that can be memorised is, 3 minimum, 8 maximum (inc. 1 MASTER). Whenever a key is replaced or added, the code memorisation procedure must be carried out again for all the keys used.

Procedure (refer to ignition switch diagram below) Insert the "MASTER" key in the switch.

Within 2 seconds, turn the key to the 'RUN' (R) position. As soon as the warning light goes out, turn back to the 'STOP' (S) position. Within 10 seconds, remove the "MASTER" key from the switch.

Insert the 1st key and turn to the 'RUN' (R) position. As

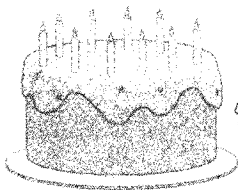

HAPPY BIRTHDAY

July 1999

Rally Supplement

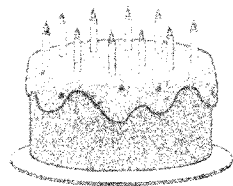

Ralliers please note that rallies start & finish at 12 noon, unless otherwise stated. Early arrivals and late leavers can invalidate our Exemption Certificate.

When completing a Rally Slip please complete BOTH sides.

Please remember that only Club members are allowed to attend our rallies.

Some people have contacted me concerning VAT and how it affects rallies. Do not worry about it. All that is required are VAT receipts for services or items used at rallies. You only have to ask for a VAT receipt when you purchase goods. The important thing is that the receipt has the shop's VAT number on. Also, when paying the rally site fees, ask the site owner for a VAT receipt. If meals or coach trips are arranged then either arrange for the ralliers to pay the supplier ie the landlord, or coach driver, direct or ask for a VAT receipt when paying the invoice.

NEW RALLY 28th - 31st October. Eastham Hall, Lytham, Lancs.

1st - 4th July (3 nights). Chirk Caravan Club Rally Site, nr. Wrexham, North Wales.
This Rally has been cancelled due to circumstances beyond our control.

2nd - 4th July (2 nights). Prestwood Steam Fair, Prestwood, Great Missenden, Bucks.
Early applications would be appreciated.

Rally Marshals: Ann & Norman Ailward.

Site Fee: £13.00 for the weekend including unlimited entrance to show. Rally Fee: £2.00.

This is a **GREENFIELD** Site. Cheques payable to Mrs. C.A. Ailward, 15 Earl Howe Road, Holmer Green, High Wycombe, Bucks. HP15 6PU. **Tel. No. 01494 713 071.**

Directions: Off A413 at Gt. Missenden take A4128 to Prestwood, follow Steam Rally signs. **Please do NOT arrive before 1.00p.m.** This is a very popular Steam Show with so much to see.

A real family treat.

7th - 11th July (4 nights). "Silly Suffolk" Reydon Community Centre, Southwold, Suffolk.

("Silly" Suffolk: from the Anglo Saxon saelig meaning happy, fortunate).

Rally marshals: Barbara & Ray Whiley.

Emergency Tel. No. 07899 853 988 (Marshals' mobile 9-10 a.m. & p.m., messages can be left 24hrs).

Site Fee: £4.00 per night. NO Electricity (Wheelchair batteries may be charged).

Rally Fee:£1.00 per van plus 50p per adult.

This is a **GREEN FIELD** site --NO toilets.Only drinking water & toilet emptying point.

Booking slips to: Mr. & Mrs. R.E.Whiteley, 21 Elcar Rise,Eaton,Norwich,Norfolk.NR4 6HR.

Tel.No. 01603 452 593. Please state the number of nights.Cheques payable to:R.E.& B.Whiteley.

The Community Centre is a former secondary school about 1 ½ miles from the centre of the ancient borough of Southwold(Charter 1489,Henry V11).The rally will be on the playing field and includes the use of a small hall for social gatherings. A short walk to the pub & village shops.

Regular bus service to town and to Lowestoft.Centre of Suffolk Heritage Coast:award winning beach,Sole Bay(battle 1672),Church of St.Edmund(1640).Home of Adnams.Very close to Dunwich,Minsmere(RSPB) & Snape Maltings.Within easy travelling distance are the Norfolk Broads,Constable Country & Earsham Otter Trust.

Directions:From North or South on A12 turn East from Wangford bypass onto B1126

(sp.Wangford).On outskirts of Reydon,soon after church on left,turn **right** into Community Centre.

16th-18th.July(2 nights). Beacon Park,Lichfield,Staffs.

Rally marshals: Tricia & Ted Pratt.

Site Fee:£4.00 per night. NO Electricity.

Rally Fee:£ 2.00.

Booking slips to Mrs.P.M.Pratt,3 Grafton Road,Stapenhill,Burton upon Trent,Staffs.DE15 9DN.

Cheques payable to Mrs. P.M.Pratt. **Tel.No. 01283 538 818**.You may arrive on Thursday evening.

This is virtually a **Green Field** site although there are public toilets in Beacon Park.

Attractions:Saturday evening get together,Jacket potato meal,desert & drinks £3.50 per head pay with booking slip. Beacon Park is adjacent to Lichfield City Centre & Cathedral. Park attractions small golf course,pitch & putt,tennis courts & bowls.

Directions:Beacon Park is situated in Lichfield just off the A51 Tamworth to Rugeley road,go around the Island with the Bowling Green pub in the middle,take A51 Rugeley/Stafford road, turn immediately **right** down Walsall Road then **left** into Lower Sandford Street, follow signs for Car Park Beacon Park through the car park keeping to the right.

23rd-25th.July (2 nights).10th Anniversary Club & Company Rally,

Three Counties Showground,Malvern.

Full details and booking form in May Newsletter.Please note the closing date.

29th-1st.August (3 nights). Abbeygate College, Nr.Chester.

Emergency Tel.No. 01244 332 077.

Rally marshals:Jean & Duncan Ellis.

Site Fee:£4.00 per night. NO Electricity.

Rally Fee:£2.50.

Booking slips to: Mr. & Mrs.D.Ellis,6 Tudor Close,Shotton,Deeside,Flint.CH15 1NY

Tel.No. 01244 812 761. Cheques payable to: D.Ellis. Saturday evening buffet & desert

£4.00 per person.Send money with booking slip.

Directions:From North M6,M56,M53 take A41 sp.Whitchurch.In approx 2½ miles after entering Waverton turn **right** for Saughton.Beware humpback bridge,carry on through village then left hand bend down hill—gates of college on **left**.

From South A41 Whitchurch to Chester. After entering Waverton turn **left** at Black Dog.
At T junction **left** over bridge then as above.

9th-13th August. (4 nights). "Possible Eclipse Rally"

You can start earlier or stay later on the main camp site, book through normal site wardens.
Emergency Tel.No. 07979 800329 (Marshal's mobile).

Rally Marshals: Dorothy & Baz Wellard.

Site Fee: £8.00 per night. NO Electricity. Rally Fee: £ 2.50.

Booking slip to: Mr. & Mrs. B. Wellard, 18 Greenwood Close, Fareham, Hants. PO16 7UF.

Tel.No. 01329 231 259. Cheques payable to: Mrs. D.A. Wellard.

Attractions: GREENFIELD rally site attached to the main camp site at Roundhill, New Forest, Nr. Brockenhurst. Possibility of sighting the eclipse (next eclipse rally in 2090!). Site is in middle of the New Forest with many attractions including:- walks, plenty of good taverns, Exbury Gardens, Beaulieu Abbey/house and motor museum, waggon rides, Bucklers Hard period exhibition plus interesting villages. Southampton and Lymington can be reached by train from Brockenhurst. Weather permitting - a coffee get together, at the time of the eclipse, on Wednesday 11th, followed by a joint lunch (B-B-Q's, picnics, or whatever).

Directions: Leave M27 junction 1 (Cadnam) and go **South** on A337 through Lyndhurst.

Three miles after leaving Lyndhurst turn **left** off A337 onto B3055 (immediately after the Balmer Lawn Hotel) following signs to Roundhill camp site in approx 1 1/2 miles on the right.

Please bring membership card for entry.

12th-15th. (3 nights). August. "Tom's Ome", Normans Farm, East Hardwick, West Yorks.

Emergency Tel.No. 01977 704 895.

Rally Marshals: Barbara & Vic Kaye & Evelyn & Ben Mansfield.

Site Fee: £ 3.00 per night. NO Electricity. Rally Fee: £2.00

GREENFIELD SITE. A toilet and water, facilities for charging wheel chair batteries.

Booking slips to: Mrs. B. Kaye, 14 Firthwood Road, Coal Aston, Sheffield. S18 3BW.

Tel.No 01246 412 679. Cheques payable to Mrs. B. Kaye.

Attractions: The Royal Armouries, Leeds, The Mining Museum, Wakefield, Medical Museum, Leeds.

Saturday night Pie & Pea Supper plus gateau in village hall. £2.50 a head. Please send money with booking slip.

Directions: Pontefract to Doncaster road A639 East Hardwick 2 miles from Pontefract.

From North turn left into East Hardwick.

From South turn right into East Hardwick. Site 400yds on left **very sharp left turn.**

19th-21st August. (3 nights). Waudbys' C.P. South Cave, Nr. Hull.

Site Tel.No. 01430 422 523 (Emergency only).

Rally Marshals: Vera & Brian McLean.

Site Fee: £3.50 per night. No Electricity. Rally Fee: £ 2.00.

This is a **GREEN FIELD** rally.

Booking slips to: Brian McLean, 47 Westlands Road, Sproatley, Nr. Hull, East Riding, HU11 4XG.

Tel.No. 01482 813 791. Cheques payable to B.McLean.

Attractions:Humberside Country Park,Beverley Market, (Saturday),Hull Art Galleries, Wilberforce Museum,Streetlife Museum,Queens Gardens, Princes Quay Shopping Centre.Trains to Brough/ Hull.Caravan accessories shop on site.Possible ramble (8 miles) on Friday and maybe a pub lunch.

Saturday evening,weather permitting BBQs/ meal on site 7.00p.m.

Directions: Turn off A63 at South Cave intersection, follow sign Brough,site opposite garage.

19th -22nd .August. (2 nights).Countryways Experience,Alford,Surrey.

Emergency Tel.No. 01403 753 589.

Rally Marshals: Sally & Jerry Haxton.

Site Fee:£ 3.00 per night. NO Electricity. Rally Fee:£1.50.

GREEN FIELD site.Toilets,emptying point and water on rally field.

Booking slips to: Mr. & Mrs.D. Haxton,"Almond Tree House",Send Hill, Send,Woking,Surrey.GU23 7HR. Tel.No. 01483 223 476.

Cheques payable to D.Haxton.

Attractions: Rally field in "Country Park" with well stocked farm shop,coffee shop,Victorian walled garden,farm museum,animals etc.

Large social club in main house with snooker and pool tables,darts.Fishing lake available for use. Bring licence.

Directions:Take A281 Guildford to Horsham road,at Alford Crossways turn off S.p. Alford.

Immediately turn right S.p. Dunsfold and follow Brown Farmcart signs to site,approx. 1 ½ miles.

LIMIT 25 Vans

26th -30th .August.(4 nights) "Wonderful Wensleydale",The Wensleydale School, Richmond Road,Leyburn, North Yorks.

Emergency Tel. No. 0589 145 874 (Marshal's mobile switched on 8-10 morning & night, messages 24hrs).

Rally Marshals: Pauline & Neil Rogers.

Site Fee:£3.00 per night. No Electricity. Rally Fee:£2.50

Booking slips to N.C. & P. Rogers,3 Appleby Close, Aldbrough-St.-John,Richmond, North Yorks.DL11 7TT. Tel.No. 01325 374 540. Cheques payable to: N.C. & P. Rogers.

Attractions:Possibility of access to room in evening.Details not yet finalised.There may be a small extra charge.

Wensleydale Show during weekend.Market day Friday.Cheese making at Hawes,violins at Leyburn,Aysgarth Falls,Middleham and Bolton Castles,Jervaulx Abbey,Racehorses on thegallops.The Black Sheep Brewery,the Teddy Bear Workshop,Tea Pottery and Dairy Ice Cream at Brymor.

Directions:From A1 North/South take the A 684 at Leeming Bar.s.p.Leyburn/Hawes.Go into town centre at Leyburn and take A6108 S.P.Richmond. School on right in approx. 300 metres.

1st -5th September. Shoreham Air Display, West Sussex. (Limit of 30 vans).

Rally Marshals Yvonne & Barry Loveland..Emergency Tel.No.on site mobile 07801 692 518.
Site Fee:£2.00 per night. Rally Fee:£2.00. Air Show tickets £10.00 per adult.£5.00 per child.
These tickets are for Saturday & Sunday inclusive,payable in advance,money with slip.
GREEN FIELD site with water and Loo emptying.

Cheques payable to A.N.Fowler.Booking slip to (*Please note new address!*):-
A.N.Fowler 20 Hawkins Close,Shoreham by Sea,West Sussex.BN43 6TL.
Tel.No.01273 594 479.

Attractions:2 day air show with on ground entertainment,bike rides & dog walks from site.
Saturday evening Buffet meal available @£2.50 per person.
Thursday evening Airport tour available @ £2.00 per person.
Thursday fixed wing flights available(groups of 3 in plane) @ £32.00 per person.
Please state and pay in advance if requiring any of the above.S.A.E. for confirmation.
Please state van model for organisational purposes.

Directions:On A27 between Brighton & Worthing leave A27 at traffic lights opposite Sussex Pad Hotel and turn into airport(this is the *only* entrance for vans).

Please do not arrive before 2.00p.m. Wednesday

3rd -5th September.(2 nights). Faversham Hop Festival,Abbey School

London Rd.,(A2),Faversham,Kent.

Rally Marshals:Joyce & Gordon Matthews.

Site Fee:£10.00 for the weekend.(Fixed payment,NO reductions for individual days).

Rally Fee:£2.00. NO Electricity. Toilet facilities.

Booking forms to Joyce Matthews,35 Preston Park,Faversham,Kent.ME13 8LH.

Tel.No. 01795 538 913. Cheques payable to G.Matthews.

Attractions:Visit the historic market town of Faversham and enjoy the Annual Hop Festival.
A weekend of entertainment-music,dancing in the streets and pubs.Leave your van on site-
only 10 min. walk into town. Plenty to do and see in this part of Kent,Canterbury-20 mins. drive,
coastal areas only 30 mins.

Directions: Leave the Southbound M2 at Junction 6 bear **left** onto the A251 to "T" junction,
¼ mile .Turn **left** onto A2, Abbey School 200yds on **left**.

Arrival time AFTER 2.00p.m. Friday.

10th -12th. Northern Motorcaravan Show,York Racecourse.

Rally Marshals:Pauline & Neil Rogers & Evelyn & Ben Mansfield plus assistants.

Rally Fee:£2.00.

The special Club rally fees are £22.00 for up to 4 nights.

To rally with the Club it is **ESSENTIAL** that you fill in an application form from MMM or Which M² Van using the special fees and mark the form **A.S.O.C** in large letters.Send this form back to the organisers,Warners, **before 20th.August**.Applications after this date cannot rally with the Club.Alternatively send your rally fee with a S.A.E to the marshals and receive an application form in return.This still has to be sent to Warners by the closing date.

Please send a rally slip with a cheque (payable to N.C. & P. Rogers) to N.C. & P. Rogers,
3 Appleby Close, Aldbrough St.John,Richmond, North Yorks.DL11 7TT.Tel.No. 01325 374 540.

17th-19th Shepton Mallet Motorcaravan Show.

Emergency Tel.No.Marshals mobile.07775 693533

Rally Marshals: Stella & Ian Ross & Dorothy & Baz Wellard.

Site Fees Special Club prices).Thursday to Sunday £23.00: Friday to Sunday £18.00.

Saturday to Sunday £13.00.

Rally Fee:£2.00

Send Rally Fee £2.00 with Rally Slip and S.A.E. to:- Mr.I.Ross,33 Grosvenor Gardens,

Upminster,Essex. RM14 1DL. Tel.No. 01708 228 075. Cheques payable to:I.Ross.

By return you will get a special booking form which should be sent to the Organisers with the site fee to obtain tickets.

There will be a "For Sale" board,bring along your motorcaravan related items for sale,and put up a postcard.

October rallies.(Details next month)

8th.-10th. Meathrop Fell Caravan Club Site.

8th.-10th. Hidden Valley C.P.

Advance Notice.31st December-2nd January,"Millenium Rally",Hidden Valley,North Devon.

If you are interested in this extremely popular rally to be held later this year then please contact Sandra & Bernie Wisely on 01271 346 400 or write,please include a SAE, to:

12 The Laurels,Roundswell Village,Barstaple,North Devon. EX31 3QY.

I am now taking rallies dates for next year,2000.If you are thinking of running a rally then please contact me.

As usual rallies can still be arranged during the year.If you are interested in running a rally then please think ahead.Good advance publicity is essential for a successful rally.Please remember to check the availability of dates with me **BEFORE** booking with a site.

New or possible rally marshals should contact me, or the area assistants, for further information or advice on running rallies.It can be fun and a very fulfilling experience.

Please note that **ALL** information concerning rallies,dates,booking of sites and rally details for the Newsletter should be sent to the Rally Co-ordinator:

**Neil C. Rogers,
3 Appleby Close,
Aldbrough St. John,
Richmond,
North Yorks,
DL11 7TT.**

Tel./Fax. No. 01325 374 540

E-Mail. ncr@thisisthenortheast.co.uk

Local assistants: Jerry Haxton (01 483 223 476) Woking,Surrey.

Jeff Worley (01 935 424 049) Yeovil,Somerset.

Rally : Date:

Your name and address(Please PRINT)

..... Post code:

Phone No.: Van Reg:

Membership No: Day/Time of arrival:
In the event of an emergency at the rally whom should we contact?

Name Phone No.

Please complete both sides of the form!

f

Rally : Date:

Your name and address(Please PRINT)

..... Post code:

Phone No.: Van Reg:

Membership No: Day/Time of arrival:
In the event of an emergency at the rally whom should we contact?

Name Phone No.

Please complete both sides of the form!

f

Rally : Date:

Your name and address(Please PRINT)

..... Post code:

Phone No.: Van Reg:

Membership No: Day/Time of arrival:
In the event of an emergency at the rally whom should we contact?

Name Phone No.

Please complete both sides of the form!

Is this your first ASOC rally? Please tick box. Yes No
Number of people in your van: Adults..... Children.....

Names of Adults.....

Names of Children (including ages).....

Extras: Please indicate which you would like, **if available:**

Electricity: Yes No Saturday night meal if any: Yes No

Have you any special needs? Yes No If Yes please specify:-

Full payment MUST accompany this slip-cheques payable to the marshal.
POST FORM TO REACH MARSHAL 10 DAYS BEFORE EVENT,IF POSSIBLE PLEASE!

Is this your first ASOC rally? Please tick box. Yes No
Number of people in your van: Adults..... Children.....

Names of Adults.....

Names of Children (including ages).....

Extras: Please indicate which you would like, **if available:**

Electricity: Yes No Saturday night meal if any: Yes No

Have you any special needs? Yes No If Yes please specify:-

Full payment MUST accompany this slip-cheques payable to the marshal.
POST FORM TO REACH MARSHAL 10 DAYS BEFORE EVENT,IF POSSIBLE PLEASE!

Is this your first ASOC rally? Please tick box. Yes No
Number of people in your van: Adults..... Children.....

Names of Adults.....

Names of Children (including ages).....

Extras: Please indicate which you would like, **if available**

Electricity: Yes No Saturday night meal if any: Yes No

Have you any special needs? Yes No If Yes please specify:-

Full payment MUST accompany this slip-cheques payable to the marshal.
POST FORM TO REACH MARSHAL 10 DAYS BEFORE EVENT,IF POSSIBLE PLEASE!

soon as the warning light goes out, turn back to the 'STOP' (S) position. Within 10 seconds, remove the 1st key from the switch.

Proceed in the same way for any other keys. Then finally: Within 10 seconds, remove the last key from the switch. Insert the "MASTER" key in the switch. Turn the key to the 'RUN' (R) position. As soon as the warning light goes out, turn back to the 'STOP' (S) position.

The code memorisation procedure does not give a positive result in the following cases:

(a) insertion of the same key twice in succession, (b) if a key remains in the 'RUN' position for more than 2 seconds, or (c) if a key remains in the 'STOP' position for more than 10 seconds.

Ignition Switch

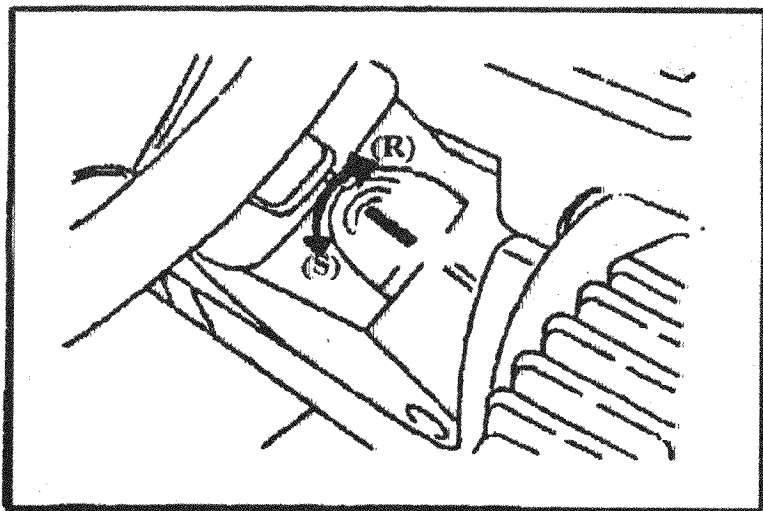

Hopefully this has thrown a little light on a complicated subject and has proved of interest. Might I close by offering the following advice. Look after your keys and don't let anyone who doesn't know what their are doing mess with either the keys or the immobiliser. Finally please be aware that the costs quoted are only

the best estimates I could extract from our local dealers and may not reflect what you might actually have to pay.

Charles Trevelyan

====ooo000ooo====

Chairman's Chat

In late May I am on the outskirts of Bath and I am writing this with a pen! This is our first visit to the town and it will be worth returning to it. We are on our way to prepare for our rally at Van Bitz in Taunton.

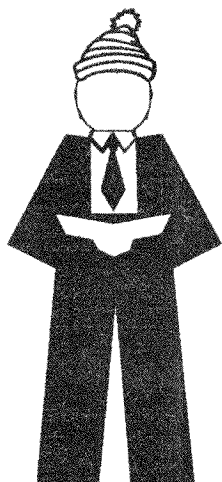

During the AGM a member, quite properly, raised the question of the increase in committee expenses. Let me explain how this has arisen. Like all of us, we must pay the increasing costs of fuel. With committee members living all over the country we converge on the Cotswolds for our meetings as it is fairly central. Most of us travel some 150-200 miles each way. Wherever possible we try to combine other duties with the meetings to economise not only on costs but on our time as well. I honestly don't know of any committee member, past or present, who has not subsidised their work in some way. We have also had various issues which needed us taking professional advice. At present you may know that we are looking into our VAT situation. Thanks to A-S we had the benefit of advice from their VAT accountant which convinced us that we needed further assistance to determine our position with Customs & Excise. We will not evade payment but we would like to avoid it because it would be simpler for us. If we must register then we can claim back the VAT which we pay to others. But on the whole we shall pay more tax. We believe that all hinges on what view is taken concerning the monies involved in rallying. Rallying makes a slight profit these days but the turnover is high when site fees for 30-odd rallies are taken into the equation. Yawn! Yawn!! Who cares? We

must! As good and prudent managers of the Club affairs.

Just a quick smile now. The scene is a Lancashire fire station. The occasion is a visit by Her Majesty's Inspectorate. We had "an informed leak" on what questions we might expect which mentioned "Hazardous Substances". The Chief Fire Officer walked into where we were lined up for the inspection. One of our "older" colleagues, a true Lancastrian with a great accent that you could cut was asked what he knew about Fluorine. He pulled a studied face then seriously replied "Well, there's concrete floorin', wooden floorin', stone floorin'". The Chief threw his cap on the floor. The inspector smiled and said that he'd heard enough and left us alone.

Travel safely and smile.

Andrew Entwistle

---==oooOOOooo==---

In Committee

The Committee met at Moreton in Marsh on May 22nd and eleven members attended.

Two papers on the Formation and Working Practices of the current Committee and two Standing Sub-Committees were considered. Boring stuff, you may think! Consider however that most members hope that the Club will run smoothly in their interests, avoiding too many banana skins, and that, if this desired state of affairs is to happen, the three groupings who do the major part of the organisation should be reviewed occasionally - even if only once a decade. An example of the type of question the papers contained. At the moment there are twelve people on the main committee of whom six stand for re-election each year. Suppose that in one year all six did not stand. The Club might then have to find, for example, a new Secretary, Treasurer, Newsletter Editor etc. all in one year. The effect might be destabilising - especially if the same thing happened the following year. Would the Club be more secure if only four members stood for re-election every twelve months and served for three years?

In order to look at this and other allied questions about the

Club Committees and sub-committees in more depth, I have been asked to form a small sub-committee. I would like some volunteers for it please! If you have relevant experience to offer and are willing to take part in the group will you give me a ring? (Tel: 0150 746 2449) I am thinking in terms of one or two meetings only to be held in the autumn, either in Lincolnshire, or the usual Committee venue in Gloucestershire.

To get back to May 22nd. The meeting addressed the issues which arose in the Open Forum at Kettering in April, finalised arrangements for the Club & Company rally in July and considered options for the AGM next year. For once there was little to discuss about VAT. That seems to have reached a plateau of waiting for replies to letters.

Janet Sutterby
Minutes Secretary

====000000000====

CREAKING

I have a 1981 Talbot Express Harmony which recently started creaking and groaning only in dry weather in sympathy with *Jackie & Daniel Hines's* van as reported last December. I had initially referred back to that issue for a possible solution to my problem but having read the article I decided that there was only one course of action I could take to avoid a very noisy long Easter trip. I needed to reproduce mother nature and soak the springs with water. Don't laugh, but it worked!!

The secret method - I filled my large 2 litre garden sprayer with water and directed the extension lance so that both sides of the rear springs and everything underneath the wheel arches was soaked. As a precaution I am storing the sprayer in the van, but we had a quiet journey at Easter and I have not heard a groan or a creak since.

Michael Warby

I only hope that the next noise you hear is not bits dropping off due to rust!

====000000000====

Cooking

Our (reasonably) tame cookery expert (?) *Nial Reynolds* has been at it again. He has now produced "Nial's Double Skillet Cook Book" which, as the name suggests, was inspired by the purchase of a double skillet from D & F Productions. This was in the spring of 1998 and since then he has been preparing the book. It contains recipes for soups, stews, egg dishes, sauces, salads, rice, pasta, meat, fish, bread, pastry, cakes and sweets. Every recipe is simply described and can easily be made by the allegedly non-cooking member of the van team. In addition, he keeps to recipes which may appear to be a bit basic when compared with those shown on television which may need 15 or more ingredients. But they are very suitable for use in the van.

He also describes some of the equipment he uses, such as knives, "food processors" etc. which could well be of great use. The price is £6.50 plus £1.00 for p&p (£7.50 in total). Still available is "Rambling Recipes" at £6.50 plus £1.00 p&p and the Easy Cook Book at £1.50 plus 50p for p&p. Cheques should be made payable to Dr. N Reynolds and sent with your order to 49 Arden Way, Market Harborough, Leics., LE16 7DB.

Copies of all of these will be available at the Club and Company Rally and you will then save yourselves the postage - as well as meeting the author!

--- == 000000000 == ---

Detling

Doreen & I wish to thank the rally marshals, *Ena & Ray Coleman*, for the efficient and pleasant manner in which they carried out their duties. They met each rallier and escorted them to their pitches. They were always on hand in case of need. Their courtesy made us all feel one happy family. At the usual coffee gathering on Sunday morning *Ray* gave us a very homely address. We would also like to thank all members attending for making this a friendly atmosphere and making the weekend such a wonderful success.

Doreen & Alfred Vance.

--- == 000000000 == ---

TOW BAR

Has anyone information, please, on fitting a tow bar to a 1991 'J' reg Talbot Express Talisman? It appears that one has to be made and can only be fitted on to the chassis extension. It seems to be very restrictive as to what can be towed. My telephone number, if anyone can help, is 0125 779 1194

Harold Cartwright

====000000000====

PS. PHONE NUMBERS

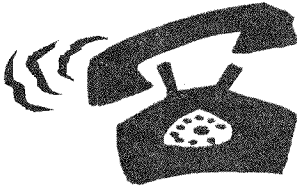

If British Telecom has changed your telephone number in the latest round of changes, effective from June 1st, please notify the Membership Secretary (if you haven't already done so).

====000000000====

OBITUARY

Ray Thornell passed away suddenly on 28th May while on holiday in Ireland. Our sympathies and condolences are offered to *Josephine* and his family.

#####

Denise Stow has written to advise that her husband *Eric* died unexpectedly on 2nd March last although he had been ill for some years. Our sympathies and condolences are offered to *Denise* and her family. She says that she will continue with the Club and has already booked for the Club & Company Rally.

====000000000====

FOR SALE



Talisman, 1986, petrol. 100,000 miles. Kept under cover. Limited slip differential, alarm and immobiliser, roof rack, Silver Screen, double glazed. New cushions and upholstery, RDS radio with 4 speakers, blown air heating. Bike rack and awning available. Excellent

condition, one owner, no pets, smokers or children. £8,000.00.
Tel: Barry Crawshaw on 0124 185 2396 or write to 32 Lochty
Street, Carnoustie, Angus, DD7 6EF.

#####

With regret - Legend 2.5 diesel automatic, 'H' reg. 42,000 miles. Meticulously maintained by fastidious non-smoker. FSH and all bills from new. Every conceivable extra - Top Box, cruise control, air suspension etc. No pets. £16,750.00 ono. Tel: Doug Williams on 0161 431 9953 or write to 137 Berwick Avenue, Heaton Mersey, Stockport, SK4 3AT.



Thanks for the donation.

#####

Having sold our lovely motorhome I am left with one item which may be of use to someone. It is a Harrison's Fiamma awning enclosure 3.5 x 7.2 x 2.25 which turns the awning into an excellent tent. We only used it one season when our grandchildren visited us in France. It cost over £300.00 but I am now beyond worrying about getting every last penny and just want someone to use it and give me what it is worth to them. I think it would be alterable if necessary. Offers to Vera Hopkins on 0159 064 3335 or write to 4 The Grange, Everton, Lymington, Hampshire, SO41 0ZR.

#####

Hope Safe-T-Bar for Clubman. One year old. Excellent condition. £125.00. Safe base with swivel. For VW T4 95/96 onwards. Used on our Clubman but will fit any T4. This is German made. Security is excellent. £100.00 - cost new £220.00. Original Silver Screen for T4 95/96 onwards. £50.00. Eurovent Autovilla free standing awning. 11 ft wide 8 ft deep. Side & rear doors. Can be fitted to a high top. £160.00 - cost new £360.00. If required I can bring these items to the Club & Company Rally. Tel: Derek Armitage on 0152 946 0231 or write

to 3 Main Road, Little Hale, Sleaford, Lincs., NG34 9BB.

Thanks for the donation.

#####



Pendal Engineering 2 x cycle carrier complete with legal lighting requirement. Will only fit vehicles with provision for a towbar. No drilling required. Can be removed complete in seconds for storage when not required. Supports each bike on its individual rail. Gives completely unobstructed view through rear window. Cost £140.00+, offered as new for only

£75.00. New, boxed and unused Auto Plus Deluxe 15" wheel trims. Cost £28.00 - offered at £15.00. Disklock to fit 42-44 cms steering wheel, i.e. most coachbuilts. This is the best available and not to be confused with the very much cheaper Autolock. This is a very visible and effective deterrent and unlike electronic alarms cannot run down your battery if the van is left unused. It also looks very smart. Complete with strong soft carrying case. Cost £118.00 - as new £65.00. New unused alloy wheelchair ramps for the disabled complete with all fittings. Cost £600.00 - offered at £200.00. New and unused Gimeg automatic gas cylinder change-over valve. £20.00. Zemco electronic compass, boxed complete and as new. £20.00. Please phone Reg Rogers on 0178 445 4400 or write to 11 Broomfield, Octavia Way, Staines, Middlesex, TW18 2QD.

#####

One set of cushions and backrests (no cab seats) in "A-S Pink" to fit old model Legend. In reasonable condition so any reasonable offer considered. Tel: Margaret & Arthur Fairburn on 0124 685 2799 or write to 93 Alma Road, North Wingfield, Chesterfield, Derbyshire, S42 5PZ.

#####

Symphony, Peugeot-Boxer 320 chassis, 2 Lt petrol. 'P' reg, '97. 12,000 miles. 2 berth, alarm, immobiliser, TV aerial etc. £20,500.00. Tel: Pat & Bob Shaw, 0151 327 4577 or write to 6 Ashtree Croft, Willaston, South Wirral, CH64 2UJ.

Thanks for the donation.

#####

Duetto, 2.5 turbo diesel automatic. Spotless example described by A-S as being of uncompromising spacious luxury. Includes Fiamma awning, Status TV aerial, Ferguson 12/240v TV, free-standing Fritrider awning. A joy to drive, registered June 1966, serviced regularly, non smokers, no pets. Under 9,000 miles. Keenly priced at £23,000.00. Also available if required (at a reasonable price) sockets and clamps plus telescopic lightweight ramps for an invalid chair. Also seeking to buy or will part exchange this vehicle for a Ravenna or Legend with overcab bed. Reasonable mileage and must be automatic. Contact Max Sayles on 0124 656 6866 or write to 76 Yew Tree Drive, Chesterfield, Derbyshire, S40 3NB.

====ooo000ooo====

TIGER NEWS

Our friends in the Technical Information Group have now got such a lot of information that it is almost impossible to contain details in the Newsletter. I would suggest that if you need any assistance of any technical nature, or if you can offer suggestions which may be of help to others, you contact their Leader who is *Maurice Payne* and who lives at 3 Chermiston Road North, Edinburgh, EH4 7BL. You can telephone him on 0131 336 3385 but you may get his answering machine.

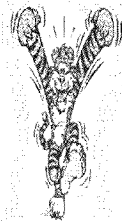

====ooo000ooo====

Contents

Photographic Competition	2	Carbon Monoxide/Tyre Failures.....	7	Cooking.....	15
HE L P !	2	Tyres.....	8	Detling.....	15
Unleaded Petrol.....	3	More on Tyres.....	8	Tow Bar.....	16
Kipper Problems	5	Vehicle Keys -continued.....	9	PS. Phone Numbers	16
Don't be a Kipper	5	Chairman's Chat	12	Obituary.....	16
Taming the Crocodile	5	In Committee	13	For Sale.....	16
Club & Company Rally	6	Creaking.....	14	Tigger News.....	19

The TENTH of the month is the last day for items to reach

Your Editor
 Harry Henthorne
 144 Devonshire Hill Lane
 London, N17 7NH
 Tel: 0181 808 9112

Any item appearing in this Newsletter may be freely used by other publications. Please acknowledge both Author and Source.

All contributions from Members which appear in the Newsletter are published in good faith in the hope that they will prove useful or interesting. All reasonable care has been taken to ensure accuracy but none of the modifications has been tested by us therefore neither the Editor, the Club nor the Company will accept any responsibility for the consequences if you try them out.

Committee Members:

Andrew Entwistle	Chairman	0142 284 3057
Pam Davies	Press Officer	0170 548 4972
Harry Henthorne	Newsletter Editor	0208 808 9112
Ben Mansfield	Chief Rally Marshal	0172 336 9769
Neil Rogers	Rally Co-Ordinator	0132 537 4540
Ian Ross	Membership Secretary & Regalia Officer	0170 822 8075
Brian Smith	Chairman AGM Sub-Committee	0148 784 1786
Janet Sutterby	Minutes Secretary	0150 746 2449
John Tidbury	Treasurer	0123 553 8593
Nora Venables		0190 233 2105
Baz Wellard	Chairman, Club & Company Sub-Committee	0132 923 1259
Ray Whiley	Vice-Chairman & Secretary	0160 345 2593
Charles Trevelyan	President	0138 685 3338