

AUTO-SLEEPER OWNERS' CLUB

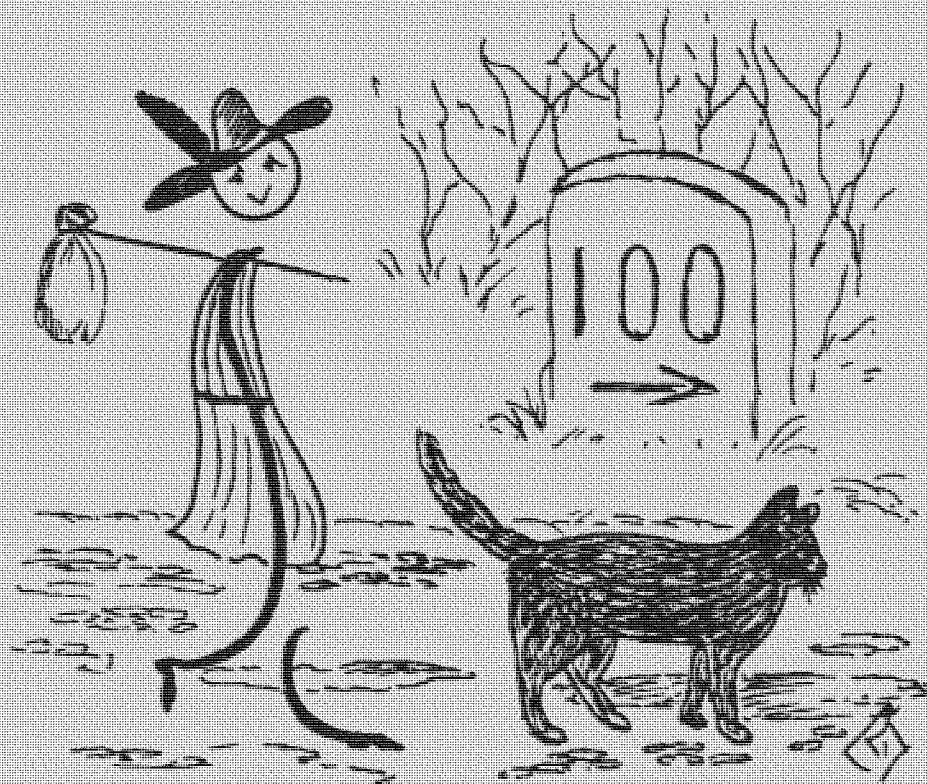

**NEWSLETTER 100
JANUARY 1997**

Hello.

A very happy, prosperous and SAFE New year to you all.

Here we are at issue number 100 - that is eight years and four months after *Phil Daley* first wrote "Greetings". What a lot of subjects **YOU** have covered in that time. As I have often said before, it is not "my" Newsletter - all I do is put together what **YOU** send to me!

#####

Let us start the New Year with a bit of nonsense. At our rally at Woodchurch in 1996 I was shown a copy of RV Times from Canada. In it were some extracts from notices found in Europe. "It is strictly forbidden on our Black Forest Camping Site that people of different sex, for instance men and women, live together in one tent unless they are married with each other for that purpose." A Czech notice showed "Take one of our horse driven city tours - we guarantee no miscarriages." And finally, from Zurich, "Because of the impropriety of entertaining guests of the opposite sex in the bedroom it is suggested that the lobby be used for the purpose." Has anyone found any similar misuse of English when abroad? I'll bet there are some equally brilliant (?) notices around.

--- = = 000000000 = = ---

"Discount Points Schemes"

You may have seen on "Watchdog" on the television how a certain scheme where points might be collected using a credit card could be used as a discount against a new car. When some people tried to cash in their points they were told that the scheme was no longer available. I have now heard from a member who wishes to remain anonymous that the Peugeot credit card includes a specific statement that the points may be used for a discount (up to £1,800.00) on the price of a "light commercial vehicle". This was taken up with Peugeot who confirm that a motor caravan is included in this deal. It remains to be seen whether anyone can spend enough on the credit card to get a discount - and is it worth while anyway. No doubt we shall hear more of these schemes from time to time, either as a warning or as a good idea!

--- = = 000000000 = = ---

A Cautionary Tale

Having read with interest *Alan Chennell's* item in the November Newsletter I decided that it was time to replace the plated screws with stainless steel ones. I removed one screw in order to determine the size required and sat by the telephone with Yellow Pages until I found a

supplier who stocked stainless steel one inch screws (I have not yet gone metric!). I visited the ironmonger 10 miles from home, purchased my requirements and on returning home started the job.

Would you believe it? The second screw that I removed was two inches in length. A quick check revealed that four sizes of screw are used to secure the windows in my "Legend". There are 68 x one inch, 26 x one and a quarter, 8 x one and a half and 6 x two inches. I returned to my supplier only to find that he does not stock two inch stainless steel screws. A check in his catalogue - none listed. I left the problem with him to be informed two days later that such screws are not produced.

I have therefore replaced the two inch screws with new plated ones, which means that every two years or so I will have to remember to replace them. Apart from the four and a half hours it took to do the job the cost of replacing the screws was much less than £10.00 including the telephone calls, two trips to the ironmonger and the cost of the sealant in which to dip the new screws before insertion in order to avoid water percolating down the thread. It would seem that the additional cost at the time of construction would be negligible to A-S and it would save owners having to do the work!

One further point, this time on Electrics.....

When watching television, if the light over the cooker/sink is switched on the television changes channel. No-one that I have spoken to about this can give any explanation. Can any member tell me why, please?

Doreen & David Palmer.

I have the exact answer to your electrical problem - go back to a manual gramophone!

====oooOOooo====

Cold Feet

Are there Clubman owners out there that are suffering from this affliction? We certainly did but now we've effected a remedy. (In other words we stopped a draught!) The causes were twofold.

A. Cold air entering the external refrigerator vent and finding its way in through the poorly sealed edges of the fridge and also via the spaces at the top and bottom of the fridge.

B. Cold air entering via a 5 inch square hole in the floor provided

for the 1.5 inch water inlet hose, i.e. above the cold water tank.

The remedies for (A) are: 1. Check that your fridge is properly secured. The security screws are located on each side underneath plastic caps just inside the front of the fridge. (Two on each side, the screws being of the self-tapping type.) 2. Seal the rear edges of the fridge via the vent with thin strips of shaped hardwood wedged into position (or use stick-on draught sealer, rubber or foam.) 3. Fill the cavities at the top and bottom of the fridge loosely with mineral wool. 4. Seal around the front of the fridge edges with a small bead of flexible sealant. Note: The front panel underneath the fridge door can be removed to gain access for inserting mineral wool. This cover can also be sealed if you wish by fitting a rubber or composite gasket.

The solution for (B) is: 1. Remove the right-hand front nearside drawer assembly. To do this it will be necessary FIRST to remove the drawer front, i.e. remove the plastic caps covering the screws on the inside of the drawer. Remove screws and the screws holding the catch on. The drawer front is held in place on a plastic spigot which can be pushed/pulled out. Having removed the drawer front locate the drawer securing screws through the holes in the outer drawer slide. You will probably have to force out the rearmost screw at the front nearside as it is not accessible. The drawer can then be gently removed. 2. Pull or cut back the carpet to gain access to the hole in the floor. Fill the hole with mineral wool and secure a two piece 7 inch square cover around the hose. The cover can be made of thin plywood, hardboard or plastic. Drill the 1.5 inch diameter hole in your cover before splitting it. 3. To refit the drawer assembly you may need to use setscrews and nuts or put a wood insert in the corner of the drawer on both sides to accept longer screws. The rear (front N/S) screw can be omitted. These alterations/modifications have been done after discussions with *Charles Trevelyan, Neville Jeffs* and other members of A-S staff. If you want to discuss them further, please phone us on 0131 336 3385. Note: It might be easier just to buy some fur boots!

Beth & Maurice Payne

I am looking forward to some more mods from these resourceful members - and not just because we have a Clubman!

-----ooo000ooo-----

Ford Legend

Last year we exchanged a 17' trailer van and our SAAB for a Legend with a 2500cc diesel engine (not turbo). On our first outing to

Scotland we wondered if we had made a mistake. First, I was disappointed when on several cross country routes we had to drop down to 2nd or even 1st to climb 15% or steeper hills. The philosophy that the slow speed enables one to "sit back, take one's time and enjoy the drive" has its merits but I thought of the tailback behind me and wished for the extra "oomph" that a turbo would have given. Through the Newsletter I have heard of the conversion by TC of Lancaster and am giving serious thought to it.

Next I became aware of the inadequate rear suspension on the 1991 Transit and I suspected the shock absorbers. I spoke to the dealer who said the previous owner had made similar comments and they had fitted new rear shocks just before he sold it back to them and they sold it to me. The only solution was to supplement the suspension and Air-Ride was recommended. This has made a significant improvement.

Finally the reduced space (compared with the trailer van) and shortage of table and shelf space. This caused some rather fragile exchanges between *Liz* and me, especially at bedtime when the double bed and Gemma, our golden retriever, took up 90% of the floor space. Getting undressed required the agility of gymnasts. We soon realised that two single beds released vital space and have slept that way ever since. We improved the table and shelf situation by making a two tier shelf to fit between the front seats (see sketch below). I also made two boxes to slide under the front seats, one for tools etc. the other for books and maps.

Having looked at the new models introduced by all the manufacturers over the last couple of years we have not seen one to meet our criteria so we shall enjoy our Legend for a few years yet.

Leighton Jones

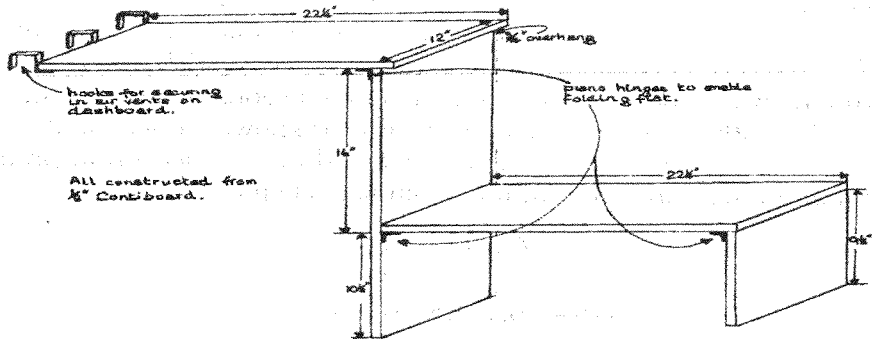

Hurrah for the European Union

Many years ago I used to collect stamps. Later I collected Green Shield stamps. Now I have a rather more practical purpose in life, and one with a more immediate payoff - beating the system. A couple of years ago I realised that there was an advantage in belonging to the EU when I found that the Spanish have the good sense to grant free entry to some of their national treasures, normally on a Wednesday, to people who have passports issued by an EU country. Among the places to be visited for free are the Royal Palaces at Aranjuez and Madrid, and there is also free entry to the Prado Museum in Madrid on a Saturday afternoon, this being for all nationalities. I preferred the Royal Palaces as walking in for free annoyed the hell out of the Americans who had to pay. *Cynthia and I* also found that there are some place in France, such as the castle at Angers which give free or reduced admission to pensioners.

However, our first visit to Italy last September and October has given us a deep admiration of that country of wonderful art and crazy drivers which has many offers we couldn't refuse. On arriving from Austria our first port of call was Grado, and from there we progressed via Trieste, Venice, Assisi, Rome, Pompeii, Paestum, Siena and Florence, before beating back home through France. It was when we arrived at the ruins of Pompeii (there is a good site within 200 yards of the entrance) that we spotted that members of the EU who are over 60 are admitted for free if they can prove both points. One flash of a passport and we were in. We may have missed out on a lot of things before then, and we certainly didn't see half of the things we could have done after Pompeii as the weather was often against us. But we struck paydirt in Florence at a tourist information office where a friendly chap handed over a list of museums, chapels and art galleries which charge admission, together with their opening hours, and obligingly pointed out which ones are free for the over-60 brigade. Armed with this priced information we saved ourselves a total of 124,000 lire in charges. As we paid 128,400 lire in tolls on the Autostrada (a much better bet than negotiating the cities), we were only 4,800 lire (about £2) down. If we'd known earlier, had more time or been even meaner I'm sure we would have ended up in profit. Isn't it about time that Britain had a similar scheme ?

Chris Fookes

====ooo000ooo=====

Help!

We are the happy owners of a 'D' reg Trident which we bought second-hand in 1992. It is our first van and although we have not been able to attend any rallies we have had many enjoyable weekends around the country. It would be a great shame if we had to sell the Trident but next year it may be necessary to replace it with an ordinary van for carrying supplies for a business that we hope to buy.

So perhaps members could help with some information about the total weight of the Trident including the sink, fridge etc. A-S have no records of the model because of their fire in 1991. Once I know the unladen axle weights of the conversion it should be possible to work out the load carrying capacity by comparison with the axle weights for a normal VW transporter (at least, I think that is the case). The last query is to ask what weight trailer could be towed once a tow hook is fitted. If anyone can help, please write to Pentrefelin Cottage, Glanwydden, Llandudno Junction, Conwy, LL31 9JP or telephone 0149 2254 8307. Many thanks.

John Rice

I believe that there is a plate somewhere in the cab area which gives the GVW (Gross Vehicle Weight) and the Unladen Weight. The difference between the two is the load carrying capacity - including People!. In our case, with the VW Clubman GL, the load permitted is 515 kg. So far as the trailer is concerned, the various caravan clubs and manufacturers usually seem to take the view that the trailer should not weigh more than about two-thirds of the vehicle weight. It will slow you down a bit but it should take the weight!

---==ooO000ooO==---

Help Again!

I wonder if any fellow member may be able to help? At this time the only bed that affords me a night's sleep free from pain is in our motor van so that is where I sleep. I would like to know if it would be possible to get a mattress of the same material. I have tried several different mattresses, had physiotherapy, seen an osteopath and I have massage - all to no avail. Apparently an X-ray shows some damage to my thoracic spine which is where the pain originates. However that doesn't make it any easier when considering all the information!

Sheila Lancaster

My immediate thought is to get in contact with the people who

made the van beds in the first place - probably Unique Furnishings. I'm sure that they would be only too pleased to make a mattress-sized cushion from the same sort of stuff. And if that was then put onto a solid wooden base like we have in the vans then, presumably, the similarity would be complete.

-----ooo000ooo-----

And Again!!

Can anyone advise on tyre pressures for the new Legend, 2.5 litre with Michelin tyres 225/7 or 15C PR6. Advice given so far is front 46 lbs and rear 54 lbs. Many thanks.

Rosemary & Mike Hill

-----ooo000ooo-----

Peugeot Boxer

On almost all the road tests on this model the tester has made the comment that storage is only provided in the driver's door. This is, of course, correct but the same door pocket fits both sides. So one can be bought for around £13.00 from any Peugeot dealer. I had mine fitted at the first service with no charge for the fitting.

Geoff Scholey.

-----ooo000ooo-----

Organising and Financing the Club & Company Rally

These details of this rally still seem to remain somewhat of a mystery to many members. At the request of the Committee this note has been produced in an attempt to explain how funds are raised and used. Also to show how the responsibilities are shared between the Club and the Company who work in partnership. The Rally Sub-committee has members from both the Club and the Company. Generally the Club looks after the indoor entertainment for Friday and Saturday while the Company sees to the outdoor events.

Financially, the cost of hiring the main hall (with the overheads of hiring chairs, tables, decoration, waste skips etc.) plus the camping charge per van gives an overall Showground cost for the event. To this is added the cost of the indoor entertainment, St. John Ambulance attendance, hire of P.A. system and the administration costs of running the rally (plaques, printing programmes, postage etc.). This total cost is then divided between the estimated number of vans attending to arrive at

a break-even rally fee.

The Company makes its own financial contribution to the event and gets financial support from some suppliers. All the money available is wholly dedicated to their costs. Any surplus is retained in a special account for use in the following year.

Income is also received from day visitors and from the traders who display at the rally. The Club policy is to encourage traders to attend for the benefit of members. Since they don't do a lot of business we do not charge a very high fee. We certainly want to maintain a large number of trade stands.

Sharing the financial responsibility and dividing the organisational work between the Club and the Company has worked very well. The aim is always to break-even and this has been more or less achieved. The Club does not maintain a separate account for the rally but the Treasurer has full details of income and expenditure.

#####

From the Company Viewpoint

Our side of the Sub-committee consists of *Tony Johnson, Neville Jelfs, Phil Bennett and me (Charles Trevelyan)*. Our responsibilities are very clear - all outdoor activities, the Stores Shop and the new vehicle display. Our input for the weekend is substantially larger than you might expect. Well beforehand a recce takes place to enable us to be quite clear as to where our new vehicle display will be sited and where the other outdoor activities will be positioned. *Tony Johnson* and *Steve Cant* together determine what vehicles are to be displayed and in what arrangement while *Neville and Phil* work out the ground layout for the other items. At the same time *Graham Mytton* and his excellent stores staff, together with *Phil*, decide what stores items should be taken and make the necessary arrangements regarding transport and security.

Our thanks go to all the suppliers, particularly Peugeot and Volkswagen, who generously donate to the rally. While much of the expense of the weekend is met by suppliers donations, the Company contribution is considerable in itself. Apart from the preparation, transport and display of the new vehicles and the Stores Shop we pay for all "official" entertainment and the hire of the building for the Stores Shop. Once contributions have been received (or promised!) we determine what activities we can afford. The type and format of displays

are agreed in the Sub-committee and we ensure that our budget is not over-spent. Our aim is quite simply to provide the best quality entertainment that we can afford for the weekend.

When the rally closes our work is by no means finished. We return to Willersey with the new vehicles and the unsold stock from the stores shop - fortunately very little! All of it has to be checked back into the stores on the Monday morning. After that it is back to making motor caravans - but our sights are always set on the Rally for next year. We always want to hear what types of events the members prefer so any suggestions you have will be welcomed by the Committee for consideration.

#####

A rough summary for the 1996 C&C rally will give an indication of how the partnership works.

ASOC

Total income from rally fees and from traders etc.		£7,748.60.
Expenditure		
Showground cost	£5,414.87	
P.A. system	305.50	
St. John First Aid post	300.00	
Plaques	232.12	
Band (Saturday night)	530.00	
Administration	<u>756.02</u>	
TOTAL		<u>£7,538.51</u>
SURPLUS		<u>£ 210.09</u>

COMPANY

Income from suppliers etc.		£5,397.38
Expenditure		
Outdoor events	£3,136.43	
Quiz	150.00	
Marquee & refreshments	1,437.81	
Sundries	<u>359.38</u>	
TOTAL		<u>£5,083.62</u>
SURPLUS		<u>£ 313.76</u>
PLUS brought forward		<u>98.70</u>
CARRIED FORWARD		<u>£ 412.46</u>

Brian Hooton, Chairman, C&C Rally Sub-Committee

John Tidbury, Treasurer

Charles Trevelyan, Auto-Sleepers Ltd

Auto-Sleeper Owners' Club. Rally Supplement.

8th - 12th January (4 nights). White Water Caravan Club Site, Stockton-on-Tees.

Rally Marshals: Pauline & Neil Rogers.

Site fee: £5.00 per night. Electricity: £2.00 per night. Rally fee: £1.50

Booking slip to: Mr & Mrs N.C. Rogers, 3 Appleby Close, Aldborough St. John, Richmond, North Yorks. DL11 7TT Telephone: 01 325 374 540

Cheques payable to:- N.C. & P. Rogers.

Attractions: Possible use of Super Pitches, Sky TV hook-up £1.00 per night. Room available. Beefeater Restaurant just outside site (25% off main menu items. Special "Emerald Card" required, details from marshals a.s.a.p.) Tees Barrage, Bird Watching, 14-screen cinema, bowling alley plus 50,000 sq. ft. of retail and fast food outlets closeby. Stockton Saturday Market. Bus stop nearby. Many local attractions with the possibility of a coach trip to Hartlepool Historic Quay & Jackson's Landing. Factory Outlet Shopping. Will arrange if sufficient numbers. Please indicate on form if interested.

Directions:- From South on A1(M). Turn off at Junction 57 signed to Darlington & Teesside. Follow A66 for 16 miles. About ¾ mile past A1045 junction, turn off Left via slip road at signpost Teesside Park. In 200 yards at end of slip road turn Left at traffic lights. In ¼ mile at roundabout continue over Barrage Bridge. Follow caravan site signs.

20th - 23rd March (3 nights); Whitewater Caravan & Camping Park, Rhayader, Powys.

Rally marshals: John & Pat Bridge.

Site fee: £4.50 per night. Elec: £1.00, only 19 hook-ups available. Rally fee: £1.50

Booking slips to: Mrs P. Bridge, "Ardwyn", Bryn Hall, St Harmon, Rhayader, Powys.LD6 5LH Telephone: 01 597 870 234 Cheque payable to: P Bridge.

Attractions: A small, well appointed site on banks of the River Wye with first class showers & toilets. Approx. 200 yards from centre of Rhayader, a small town in the heart of the Welsh Mountains, boasting a Leisure Centre with swimming pool; the Royal Welsh Crystal Glass factory and the Red Kite feeding centre.

Directions: From Rhayader take A44 (A470) S.P. LLANGURIG. Site on left in approx 200 yards.

Limited to 40 vans. (Skateboards NOT allowed!)

Revised rally list for 1997

&

Dates for your diary

Jan. 8th - 12th	White Water Caravan Site, Stockton-on-Tees.**
17th - 19th	Outdoor Leisure '97, Shepton Mallet
Feb. 15th - 23rd	Boat, Caravan & Leisure Show, National Exhibition Centre
Mar. 20th - 23rd	Wyeside Camping & Caravan Park, Rhyader, Powys. **
31st	Easter Monday
Apr. 4th - 6th	A-S O C Annual Dinner Rally & A G M, Kettering
11th - 13th	Hidden Valley, Nr Ilfracombe, N. Devon
18th - 20th	Motor Caravan Jamboree, Brands Hatch.
25th - 27th	National Motorhome & Tourer Show, Peterborough
May 1st - 5th	Burn Gliding Club, Burn Village, Near Selby, N. Yorks
5th	May Day Bank Holiday
8th - 11th	Little Cotton Farm, Dartmouth, Devon. **
9th - 11th	Longleat Estate, Nr. Warminster, Wilts.**
9th - 16th	<i>Holiday Rally, Isle of Avalon, Glastonbury, Somerset</i>
23rd - 25th	Bentley Wildfowl & Motor Museum, Halland, East Sussex.
26th	Spring Bank Holiday
30th - 1st June	St. Pierre Caravan Park, Portskewett, Chepstow.**
Jun. 2nd - 9th	Scottish Holiday Rally, Oban, Argyle
5th - 8th	Cartmel Racecourse, Nr. Grange-over-Sands, Cumbria.**
6th - 8th	Motor Caravan Fair, Stratford-upon-Avon Racecourse
11th - 15th	Farm Meadow Caravan & Camping, Banham Zoo, Norfolk**
13th - 15th	Morecambe Bay Traction Engine Club, St. Michael's, Preston **
19th - 22nd	Camping & Caravan Club Site, Cambridge**
20th - 22nd	Carrington C.P., Milford-on-Sea, Lymington, Hants
20th - 29th	<i>Holiday Rally, The Buckle C.P., Seaford, East Sussex</i>
26th - 29th	Meadow Park (formerly Bass Meadows), Burton-upon-Trent
26th - 1st July	Nidderdale Showground, Pately Bridge, N. Yorks**
Jul. 11th - 13th	"Club & Company Rally", Malvern.
18th - 20th	Abbeygate College, Chester.
24th - 27th	Holme Valley C. & C.P., Holmfirth, West Yorkshire**
31st - 5th Aug	Cotswold Gathering, Moreton-in-Marsh, Glos(Greenfield site)**

(continued...)

Aug 15th & 16th **Detling Transport & Country Festival**, Maidstone, Kent. **
 25th Summer Bank Holiday.
 27th - 7th Sept Probable dates for **German Rally** - confirmation March/April.
 29th - 5th Sept *Holiday Rally*, **Moreton Glade**, Dorchester, Dorset.
Sep 5th - 7th **Highlands End Farm**, Eype, Dorset.
 7th - 14th *Welsh Holiday Rally*, **Brynich C.P.**, Brecon, Powys. **
 12th - 14th **North of England Motorhome & Tourer Show**, York
 19th - 21st Motor Caravan Show, Shepton Mallet.
 26th - 28th **Howgill Lodge**, Barden, Nr. Skipton, N.Yorks **
Oct. 10th - 12th **Whitchurch Cricket Club**, Whitchurch, Salop.
Nov. 28th - 7th Dec. Holiday Show, Earls Court, London.
Dec. 31st - 2nd Jan 1998 **New Year Rally**, Ilfracombe, North Devon.

Items in **bold type** are Club rallies or are National events with a Club presence.
Holiday Rallies, in italics, are Club events other than weekend rallies.
 **New venues for 1997.

Isn't it great to see so many rallies at sites completely new to the Club? New marshals are sending details right and left (well, nearly!). This causes some problems for Bob, Gordon (who organises the plaques) and me because, no sooner do I get out a revised list than in comes just one more! Don't get me wrong, it's a problem we're very happy to live with - just keep them coming. This month I have managed to include a revised list in the supplement but, as you can see, in the next few months there just won't be any spare space. I'm trying to work out a way to keep keen rally-goers up to date by some means that is not too expensive or labour-intensive. Keen types may offer helpful suggestions at any time (please). *Phil Daley.*



Rally: Date:
 Your name and address (please PRINT)

 Post code:
 Membership No: Phone No: Van Reg.
 Day & approx. time of arrival
 In the event of an emergency at the rally whom should we contact?
 Name: Phone:

Please complete both sides of the form!

An appeal for help

Do you ever go to the big events organised by the Motor Caravan Press? Many Club members go to them and, when we can supply the marshals demanded by the organisers, they get preferential rates as well as being grouped together in an area set aside for A-S O C members. We already have Marshals for the two events organised for and on behalf of the Motorcaravan Motorhome Monthly, namely the National Motorhome & Tourer Show at Peterborough and the North of England Motorhome & Tourer Show at York. So far we have no volunteers to Marshal a Club area at Shepton Mallet on 17th/19th January for Outdoor Leisure '97, nor for the Motor Caravan Fair, at Stratford-upon-Avon Racecourse, 6th/8th June, nor for the also very popular Motor Caravan Show at the Royal Bath & West Show ground, Shepton Mallet on 19th/21st September. Our seeming lack of support for the three events organised by Stones Leisure (and it certainly isn't real) is a cause of great sadness to Bob Griffiths, Editor of Motor Caravan World, which is a pity. If you intend to go to any of these and would consider making up a team with another member to do the rally marshals' job (it's too big a job for just two people) you could do your fellow members a good turn (they'd get lower rates) and, best of all, our marshals have their fees paid by the Club. Go on, ring Bob and tell him you will - what have you got to lose?

Rally Co-ordinator:-	Bob Brindle	01 777 711 588	(Retford, Notts)
Local assistants:	Jerry Haxton	01 483 223 476	(Woking, Surrey)
	Stella Ross	01 708 228 075	(Uppminster, Essex)
	Jeff Worley	01 935 240 49	(Yeovil, Somerset)

The rally supplement is prepared by
Phil Daley, 46 Ulverley Green Road, Solihull, West Midlands B92 8BQ

X

Is this your first A-S O C rally? Please tick box YES NO
Number of people in your van: Adults Children
Extras: Please indicate which you would like, if available:
Electricity: Yes No Saturday night meal if any: Yes No
Have you any special needs? Yes No If 'Yes', please specify:-

.....
Payment MUST accompany this slip - cheques payable to the marshal.....

POST FORM TO REACH MARSHAL 10 DAYS BEFORE EVENT, IF POSSIBLE - PLEASE!

(Have you completed the other side?)

RALLIES

One of our members, a self confessed non-rallier, has written to say that he and his wife use their Talisman quite a bit, usually visiting Caravan Club sites. He always makes a point of speaking to other A-S owners and sometimes find that they have joined the Club but dropped out after the first year. They seem to feel that to be a member they must go to rallies.

Nothing could be further from the truth! Many of our members never come to rallies but still enjoy being members. [Dare I say it's because of the Newsletter?] So please, if you are one of our newer members, never feel any compulsion to attend rallies, write items for the Newsletter or anything else. The prime consideration of our founder members was to make the Club easy going and for members to do what THEY want!

#####

Take 33 Vans...

This is not a quote from Mrs Beeton, but a rather more practical recipe for an Irish holiday. *Barbara and John Cox* had organised an ASOC rally in 1994 and, far from deterred by this had determined to repeat the event in 1996. Arrangements were initiated in October 1995, and a limit of 25 vans was set. However, such was the interest from those who had attended the first rally that this was quickly raised to 35, and when the Newsletter announced the event some members were too late to book and found themselves on a lengthening reserve list for a rally of 25 nights.

Inevitably there were cancellations, but eventually 33 proud owners assembled at the first site outside Garretstown near Kinsale, which is not too far from Cork. They came from the ferries from Cork, Rosslare and Dun Laoghaire - they had arrived in Ireland a week beforehand, on the day, a day (or even two) late - they were going to leave early, on the due day, or have an independent holiday - they were in A-S vans of all shapes, layouts and sizes - on every manufacturer's chassis - of all ages from Admirably Agile A-Reg, to New and Nice N-Reg (which was a few days old and being run-in). The ralliers varied from old friends to timid first-timers; there were the single ladies, the single man, the retired couples (with or without dogs) - and even that occasional rarity the employed family who had the sympathy of the footloose and fancy free. Two things were shared by all. The first was

the intention to have an enjoyable holiday; the second, the appreciation of how the sheer quality of an A-S van would contribute to this.

Probably the most enjoyable aspect of the rally from the novice's viewpoint was the total lack of regimentation. There were two 'Gauleiters' at each site who directed people to the pitches which had been allocated, and the dreaded *Barbara Cox* was seen with clipboard (no problem), and occasionally with a purse as well (an expensive problem) but otherwise it was very much "go as you please". 5 nights in Garrettstown included an organised bus trip to Cork, but many people also went to a Steam Fair at Upton, which was excellent. From Garrettstown the rally moved on to Eagle Point, Ballylickey, which is just outside Bantry, and although the weather was not too good many people enjoyed a tour of the Ring of Beara, where speeds of up to 30 mph were attainable on some of the minor roads. Then to Flesk Muckcross near Killarney, and met the best toilet block ever encountered. Nevertheless some people still preferred to use the toilet and shower facilities in their own vans.

The marauders moved on to Lahinch, a popular coast resort south of Galway, and after a convivial meal on the first night we enjoyed a relaxing stay before moving on to the next site on the shores of Lough Ree near Athlone. A night of Irish dancing had been arranged; in October by *Barbara*, and on the very afternoon by the Site Owner - "Sure and it's no problem" - which luckily turned out to be true.

By this time everyone had got used to the twin facts that advice and help were always on hand from a most gregarious bunch of fellow enthusiasts, and that 'do as you please' was the keynote of the exercise. Bird watching - of course; museums - certainly; shopping - definitely; rambling - for miles. I doubt if there was a single local attraction which wasn't visited by at least one of the company. The final site was at Roundwood, 20 miles south of Dublin, and getting there meant crossing the Wicklow Mountains via either the Wicklow or Sally Gap. This site had no electricity, but this was not a problem since the vans run perfectly well without the benefit of 'electric string', however useful you may think it to be. A final meal, a final trip to Dublin and the rally was effectively over. But as the members dispersed, the most frequent comment was "See you at the Club and Company" (Rally at Malvern), but that recipe begins with "take 440 vans...".

Chris Fookes

This was written originally for the A-S Company magazine but as it wasn't used here it is for all to enjoy. *Chris* also tells me that he knows

something of sites in Italy so if you want information please drop him a line to 41 Black Oak Road, Cyncoed, Cardiff, CF2 6QT. I suggest writing because he said that "shortly" *Cynthia* and he are off to (1) Germany, (2) Australia via Bangkok, returning via Malaysia and (3) anywhere else that takes their fancy. So don't hold your breath while waiting for a reply!

#####

THE DINGWALL RALLY

While attending this rally we were invited, by *Madge Cadby*, to have a drink in memory of her husband, *Tony*, who had sadly passed away on 23rd September. Although some of us did not have the privilege of knowing *Tony* personally, we feel sure that he must have been a rather special person to have suggested that we make this a happy occasion. We all gathered outside *Ina & Roy Coleman's* van where we were offered sherry and savouries. We drank a toast in memory of *Tony*. With *Madge* he had hoped to attend this rally but sadly it was not to be.

Daisy Wane

#####

Around 60 people thoroughly enjoyed themselves at this rally in October. Many sincere thanks are due to *Betty & Geoff Scholey* for arranging all the details so efficiently. On Thursday afternoon we all gathered together to honour the last wish of the late *Tony Cadby* which was that we all had a glass of sherry with some nibbles in his memory. This was a happy occasion when we remembered all the rallies that he and *Madge* had been to and enjoyed so much. *Roy Coleman* said a few sincere words to express our feelings. Our sincere thoughts and good wishes for the future go to *Madge* at this time.

Maggie Midgley

These two reports say it all. The rest of the Club members will join in the last sentence too.

#####

Betty and I have now been ASOC members for three and a half years during which time we have attended over 40 rallies. As those of you who know us are aware, we spent 30 years as publicans, hoteliers and cafe proprietors and have met and dealt with thousands of members of the public. We can, in all honesty, say that we have never in our lives met a nicer set of folks than we have on these rallies.

Also, we have 'had a go' at running rallies. The first one was the 1995 Spanish Rally in February. It lasted 28 days - a bit ambitious for the first time. Must have been OK as 23 vans booked there and then for

1996. We called it the Auto-Sleeper Friends Meet. About that time some members were complaining to the Committee about rallies being full before they were in the Newsletter. The solution for me was (through the Newsletter) to invite members to join *Betty and myself* in Spain for the whole of February in 1996. This absolved the Club from any blame. I must say at this stage that no one was turned down and some members joined us in Spain and were made more than welcome. This method has also been used for the third year in 1997 with the approval of our Rally Co-ordinator. 29 vans have reserved space at "Los Gallardos".

Now to our Scottish rally at Dingwall, from which we have just returned. [This was written in October - Ed.] The pleasure it gives to the marshals when all the planning and thinking works out well and the happiness is expressed on the faces of the participants of the rally has to be experienced to be understood. For this *Betty and I* say thank you all. Our message to anyone thinking of being a marshal is to 'have a go' as we did. You will worry a bit but it's worth it in the end.

Geoff Scholey

Having run a few rallies ourselves, *Sheila and I* can agree with the suggestion of having a go at marshalling. If you are still not too sure, why not ask whether you can assist a marshal at a rally to learn the ropes?

====ooo000ooo====

Chairman's (Reminiscent) Chat

"Greetings.

We have certainly been given GO for LAUNCH as far as the Club is concerned. The response has been so good we are wondering just what *John (Cox)* has started."

These are the first words of the then Editor in the first Newsletter in September 1988 which consisted of just 2¼ A5 pages compared with the 20 pages in this issue, No. 100.

There have only been two Editors, *Phil Daley* for the first 20 or so editions before *Harry Henthorne* took over the job which he holds to this day. They have produced most interesting, informative and sometimes provocative Newsletters and I, on your behalf, thank them both most sincerely.

I have been looking through the previous 98 Newsletters (I await No.99) and they have reminded me of the subjects that have appeared. There have been innumerable tips, hints, gadgets, recipes, poems,

travel experiences and advice, fuel consumption problems, discussions on tyre pressures (has this ever been resolved?), central and door locking, safety precautions, gear boxes, water heaters and pumps, items for sale and wanted (these take up almost as much space today as the whole of the early Newsletters!), cruise controls, gas - both propane and butane, Green Cards, Eurocheques and cheque cards, fridges, ferries, electrics (come to the Annual Dinner and 8th AGM Rally in April 1997 and listen to representatives of several suppliers of electrical fittings in A-S vans followed by a Question and Answer session when you can raise any problem you may have), roof vent struts, winterisation, etc., etc. What a range of topics and so much helpful advice.

There have been reports on rallies ranging from those in the United Kingdom to those in France, Spain, Ireland, Holland and Germany together with many, and varied, viewpoints on rallies. I have read, again, interesting items such as the need to purchase a ScanPrinter in Newsletter No.39, to be used in the printing of the Newsletter when we needed 600 copies. Today about 1500 copies are printed. The article went on to list, with technical jargon, the part computers played in the preparation of Newsletters and in No. 63 I read that ink, costing £0.000746 was used in the printing of one page of the Newsletter. It costs more today, no doubt. There were articles on loos, installing them using them (you know what I mean!) and cleaning them and this gives me an opportunity to repeat one of my pet grievances. **DON'T** wash **YOUR** toilet or cassette at the drinking water point on a camp site. You can do as you like in your own home.

Some great sketches have appeared on the front cover, starting with No.3, from *Rita Daley* in which she has cleverly used the initials ASOC in a topical way. Long may these sketches continue. It has amused me to read "How to know you are getting old" in No.67; "Ten Commandments, with a p.s." in no.58; "A Member's Guide to Rally Marshals" in No.57; and "Some of Life's Golden Rules" appeared in No.62. "Definitions of a Senior Citizen" were listed in No.24 with additions in No.27 and "Advice on how to keep a husband" was given in No.39. whatever happened to "Phil's Rabbit" and did *George Wane* get a refund on his servicing charges in July 1991? A professional fire fighter listed "Fire Precautions" in No.25. Do they need updating, *Peter (Fisher)*?

No.4 reported 105 places had been booked for the first National Rally and No.6 advised 50-100 more pitches were required. In

September 1993 there were almost 1,000 members (i.e. vans) and today there are in excess of 1,400 member vans - some 2,800 members. From these facts you can see the point of the Editor's opening words in the first Newsletter.

Rather than look out of the window at the fast falling snow (I write this in November) I looked through my past Newsletters and have really enjoyed the time spent. Needless to say I still have to go out and clear over 20 cms of snow from the van, the car and the path. (Later - glad I did because after a partial thaw the next day there was a heavy frost which made all the uncleared surfaces treacherous). I have only mentioned a comparatively few items and know I will have missed out an item that you may think I should have included - but it is the Chairman's reminiscences!!!

This Chat has been about the past life of the Club so, finally, I pose the question "What are you doing on 8th July 2000?" Attending the Club and Company Rally at Malvern, hopefully! Our bookings there are up to the year 2000.

Winifred joins me in wishing you a bright and prosperous New Year enjoying your A-S motor caravan.

Arthur Irving.

---==coc000ooo==---

DROOPS AND BUBBLES

Like *Joyce and Gordon Pearce* we too found that the heat deflector over the hob in "Wayside Rose", our Rambler GL, drooped - and not only when using the grill or oven. I solved the problem by gently nipping each segment of the hinge with flat-nosed pliers. This was well over a year ago and the deflector still stays at the required angle and also folds easily. Two or more very gentle nips are better than one heavy squeeze. It's better to start at the ends and work inwards, checking after each nip as I can think of no way to loosen the hinge again should it become too tight. You have been warned!

Another problem! has any other member found that the "wood" veneer on van furniture develops bubbles, like badly stuck wallpaper? This has happened on three panels and may have been caused by leaky roof two years ago. Is there a remedy? I have toyed with the idea of applying a warm iron, like sticking on edging veneer, or cutting a slit and injecting glue but I suspect that the veneer is printed plastic. I would

rather keep the bubbles than cause further damage. Any suggestions would be welcome.

Ray Whiley

====ooo000ooo====

THE NEW LEGEND

A bit of information which may be of use to other members. We bought our Legend on 1st February 1996 and as no Owner's manual was available I phoned the technical department at the Orchard to find the load capacity of the vehicle. I was quoted 351 kg but through that this was a bit low especially when comparing it with the Amethyst and Excelsior. The same base vehicle but I thought that as the Legend was some 5 inches longer the extra weight incurred would account for a reduced payload. When (finally) I got the manual I found that it quoted 441 kg as the load capacity! I wrote to the factory and they confirmed that the newer, higher figure was the correct one. However the lower figure is the one which has been quoted in all the commercial magazines but this apparently will be rectified in the near future.

My Legend has been on a weighbridge fully loaded with fuel, water and all that we carry. It is well within the MGW weight of 3300 kg. I know that some people do weigh what they carry in their vehicles in order to comply with the MGW but don't use a weighbridge. As an ambulance man for 32 years I am only too well aware of the necessity to load vehicles correctly and have witnessed the result of many accidents where non-compliance has resulted in fatal or serious injuries with all types of vehicles. Couple to this the fact that the police are now doing spot checks and it means that we must all take care for the safety of ourselves and others.

Howard Walters

I sometimes wonder about some farm vehicles carrying straw and the like. They look top-heavy and overweight to me and, at times, I've seen them leaning to one side too.

====ooo000ooo====

Ladder Guards

You may remember that *Les Davies* was making these under the tradé name of "Leros Desigus", *Les* now tells us that he has sold that company and has become semi-retired. But he is still making the useful

ladder guards under his own name. If you want one, or for more information, telephone him on 0174 376 1318 or write to him at 53 Lower Cross, Crosshouses, Shrewsbury, Shropshire, SY5 6JU. [And just try saying that address properly when you have just had a drink! -Ed]

-----000000000-----

Obituary

Mary Doody telephoned to advise that her husband, *Mike*, had passed away peacefully at home on 9th November while watching a rugby match on TV. He had been in poor health since a heart attack 2 years ago, but always kept going and enjoyed life to the end. Our sympathies and condolences are extended to *Mary* and her family.

-----000000000-----

FOR SALE



Ford Kombi Duetto. 2.5L diesel with PAS. 2 berth luxury LWB Hi-top. 'M' reg. (Aug. 94) 30,000 miles. Shower, electric flush cassette toilet, swivel passenger seat with security safe, heated drivers seat, heated windscreen, blown hot air heating, twin batteries with charger, glass fronted oven with grill, crockery for 4, 3-way fridge, double glazed with blinds and fly screens, gas/240v water heater, Omnistor Fiamma awning and twin cycle rack Status aerial with amplifier, Van Bitz

Foxguard alarm, front nudge bars with twin Lucas FX150 spot lamps, alloy wheels. No pets and non-smokers. £22,995.00 or exchange for 2 berth

Clubman, Talisman or Executive. Joan and Lewis Gell, The Penthouse, 64 Lemon Tree Court, Clifton Drive

North, Lytham St. Annes, Lancs., FY8 2 SU or telephone 0125 340 2418.

Thanks for the donation.

#####

Ford Legend 1989. 2/4 berth. All the usual features of this sought after model plus Omnistor awning and 2 bike rack, both as new. Many extras. Non-smokers, no pets. MOT November 97, taxed to march 97.

Regularly serviced, excellent condition. £14,250.00 ono. Telephone Eileen & Ken Birt on 0130 578 6058 or write to them at 95 Coldcroft Road, Weymouth, Dorset, DT4 0EA.

Thanks for the donation.

#####

Talisman GL 1990. 36,000 miles. Petrol. 2/4 berth. Taxed, MOT one year. Used regularly. Usual standard of excellence which includes heater, shower & cooker. TV aerial, Omnistor awning and many extras. £15,500.00 ono. Please contact Mary Doozy on 0175 286 2202 or write to her at Bayfield, Manor Bourne, Down Thomas, Plymouth, PL9 0AS.

#####

Peugeot-Talbot Symphony 1.9 diesel. 1994 'L' reg. 19,000 miles. One owner. 2 berth. Second battery, waste tank, alarm. Also Cabanon free standing acrylic kitchen tent, cooker stand, electric cooker. Silver screen to front, rear and wheels. Spare wheel trims. 4 gas bottles. Many extras. Non-smokers, no pets. Illness forces sale. Telephone Bill Buttery on 0192 257 7726 or write to him at Flat 4, Maple Court, Nockly Park Road, Abridge, Walsall, West Midlands, WS9 8LL.

Thanks for the donation.

#####

Due to recent change of vehicle the following are for sale. Wooden bunk ladder - £15.00. Spare fuel filler cap (Peugeot-Talbot diesel) - £2.00. Silver Screen, double insulated, truck mirror version - £35.00. Waterproof spare wheel cover, 16 inch size - £5.00. Metal step non slip foot stool - £5.00. Set of 4 fan belts for Peugeot Talbot - £10.00. Telephone John Wheller on 0138 737 5459 or write to him at Hillview, Pathhead, Newcastleton, Roxburghshire, Scotland, TD9 0RZ.

Thanks for the donation.

#####

J & M Designs Silver Screen for VW T4 (ex Clubman GL). £35.00. Telephone Clive Benton on 0127 179 803 or write to him at 3 The Orchard, Tew's Lane, Bickington, Barnstaple, Devon, EX31 2JU

#####

An odd occurrence. We went to collect an item from the sorting office and when we wanted to come home the VW Clubman wouldn't start. Called out the RAC who gave us a jump-start and said that the battery had failed, apparently a known VW problem. A replacement cost us £173.00 including delivery and fitting. But there had been no warning, no sluggish starting, no lights dimming - it just went! You have been warned!

Now just print this off, wrap it up and send it to our printer so that he can enjoy his Christmas too.

Your Editor
 Harry Henthorne
 144 Devonshire Hill Lane
 London, N17 7NH
 Tel: 0181 808 9112

Any item appearing in this Newsletter may be freely used by other publications. Please acknowledge both Author and Source.

All contributions from Members which appear in the Newsletter are published in good faith in the hope that they will prove useful or interesting. All reasonable care has been taken to ensure accuracy but none of the modifications has been tested by us therefore neither the Editor, the Club nor the Company will accept any responsibility for the consequences if you try them out.

Committee Members:

Steve Bender		0129 568 0279
Bob Brindle	Rally Co-ordinator	0177 771 1588
Andrew Eastwold	Vice-Chairman & Joint Chairman, ACM Sub-Committee	0142 284 3857
Sheila Henthorne	Club Secretary and Membership Secretary	0191 808 9112
Harry Henthorne	Newsletter Editor	0181 808 9112
Brian Houston	Chairman, C&C Sub-Committee	0123 576 4782
Arthur Irving	Chairman & Joint Chairman, ACM Sub-Committee	0114 236 3678
Ben Mansfield	Chief Marshal	0172 336 9769
Nial Reynolds	Public Relations Officer	0185 843 2811
Ian Ross	Regalia Officer	0170 822 8075
Janet Satterby	Minutes Secretary	0150 746 2449
John Tatbury	Treasurer	0123 552 5730
Charles Trevelyan	President	0138 685 3338